

G Series

INTERNAL GEAR PUMPS | PRODUCT BROCHURE



Blackmer

Where Innovation Flows



Blackmer® G Series Internal Gear Pumps are durable, flexible and efficient positive displacement pumps that excel in challenging fluid-handling applications. They are a high-quality, reliable alternative to competitive models, backed by an unmatched five year warranty with responsive and experienced factory support.

HIGH-QUALITY,
RELIABLE
ALTERNATIVES
TO COMPETITIVE
MODELS

Blackmer® G Series Internal Gear Pumps

When you expect more from your current gear pump, Blackmer G Series Internal Gear Pumps have you covered. G Series positive displacement gear pumps have the durability, flexibility and efficiency you need to safely and securely handle all your challenging fluid-handling applications. Available in jacketed and non-jacketed construction, Blackmer G Series Pumps offer a full portfolio of options and sizes to outfit your entire facility. When it's time for an upgrade, replace your current pump worries with a durable, flexible and efficient solution that provides peace-of-mind performance backed by superior and experienced customer service and factory support.

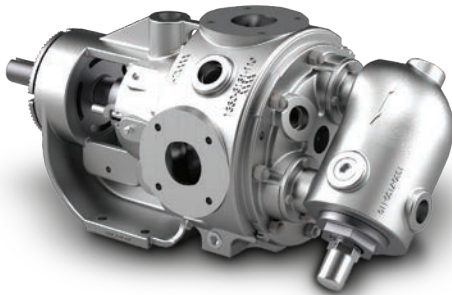

Not only does the Blackmer G Series Pump offer the best lead times and warranty in the industry, but its manufacturing quality and price are unmatched. Designed with direct competitor interchangeability in mind, G Series Pumps are second to none. Simply put, you cannot find another internal gear pump that offers a lower upfront cost, lower total cost of ownership or less risk than the G Series.

World-Class Manufacturing Facility

- **Manufacturing:** All Blackmer Pumps are assembled and tested in Grand Rapids, Michigan USA.
- **Supply Chain:** Every component that goes into an Blackmer Pump is put through a rigid Production Part Approval Process (PPAP) that ensures quality and reliability.
- **Quality Manufacturing:** 100% of Blackmer Internal Gear Pumps are tested for flow, pressure and power before leaving the factory. The facilities are ISO 9001/14001 compliant, and feature state-of-the-art coordinate-measuring machines and 3D-scanning equipment that ensure the highest level of part quality.
- **Testing Capabilities:** The R&D and testing laboratory is compliant to Hydraulic Institute 3.6 Standards, providing certified performance, NPSH and hydrostatic testing.
- **Global Support:** A full-service global distribution network is ready to serve new or existing Blackmer Pump installations and is backed by responsive factory support.

Competitor Pump Interchangeability

G Series Pumps are interchangeable with up to 95% of the mechanically sealed, packed and seal-less internal gear pumps in use today. Replacing an existing pump with a G Series usually requires no modifications to the piping, driver, baseplate or coupling, while keeping flow rates unchanged. Whether jacketed or not, G Series Pumps are designed to be part-for-part and pump-for-pump replacements for many competitive models including Viking® and are available in cast iron, carbon steel and stainless steel.

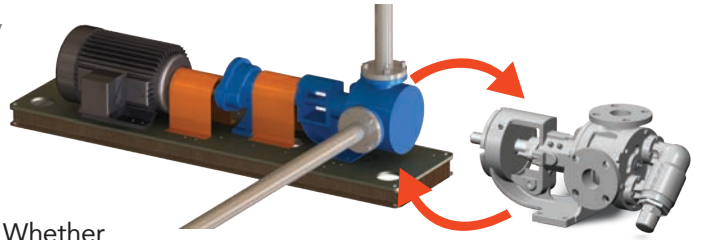

Direct Replacement Part Interchangeability

G Series parts are designed to be direct replacements for many competitive models including Viking® H, HL, K, KK, L, LQ, LL, LS, Q and QS models. This parts interchangeability applies to jacketed and non-jacketed G Series Pumps*, carbon steel and stainless steel construction. Most parts ship within 3-5 business days. Expedite programs are also available.

* Jacketed G Series Pumps available in cast iron and in sizes 55 through 222.



Jacketed

Jacketed options are available for G Series sizes 55 through 222 in cast iron construction. Jacketed pumps keep liquids with high freeze points moving through the pump, and prevent liquids from hardening. They help to maintain the process temperature and integrity during operation, providing temperature control and stability. G Series Pumps offer jacketing flexibility not found in competitive models. The following G Series Pump components have the option of being jacketed - Bracket (standard), Head (optional), Relief Valve (optional), and Case (optional & only available for sizes 55 and 133).

Warranty Info

All Blackmer Internal Gear products (pumps, accessories and parts) are backed with an industry leading five year warranty. Each and every product manufactured by Blackmer® is built to meet the highest standards of quality. Blackmer warrants that pumps, accessories and parts manufactured or supplied by it to be free from defects in material and workmanship. For more details please refer to the Installation Operation Maintenance Manual.

Delivery

How soon do you want your Blackmer G Series Gear Pump and parts? Blackmer builds and ships out equipment fast. Blackmer Internal Gear Pumps have a 15-day lead time. Our parts have a 5-day lead time, and our basemounted units have a 20-day lead time. Can the other brands do that?

Industry Leading Customer Service and Factory Support



5-Year Limited
Warranty



15 Day Factory Lead
Time for Pumps



5 Day Factory Lead
Time for Parts



Competitive Prices



ATEX, CE, FDA and
TR CU Compliant

BLACKMER® G SERIES INTERNAL GEAR PUMPS

1 Single-Point End-Clearance Adjustment

A threaded bearing housing allows the rotor end clearance to be adjusted with simple hand tools in order to compensate for wear and restore optimal pump performance.

2 Seal Chamber with Universal Design

An oversized bracket and seal chamber allows the acceptance of numerous sealing technologies, including packing, component mechanical seals, cartridge mechanical seals and lip seals. The seal chamber also accepts various seal flush-plans.

3 Heavy-Duty Oversized Bearing Housing

The cast-iron bearing housing is guaranteed to last the life of the pump, while competitive pump models use low-strength, low-cost aluminum bearing housings that can be prone to early failure. The large size of the G Series bearing housing also allows the mechanical seals to be removed without the need to take the pump out of service.

4 Materials of Construction

Wetted parts are available in cast iron, carbon steel and stainless steel to meet application requirements. See material of construction table for more details.

5 Flexible Case Orientation

Bidirectional performance for loading/unloading applications and the ability to rotate in 45° increments for eight unique port positions.

6 Internal Clearance Options

A wide range of internal clearance options are available to offer optimal performance in a wide range of applications.

7 Hardened Idler Pin

Standard on all sizes with multiple materials of construction available.

8 Pressure Relief Valve

Multiple options are available to protect the pump from over-pressure conditions. Pumps can also be ordered without a pressure relief valve.

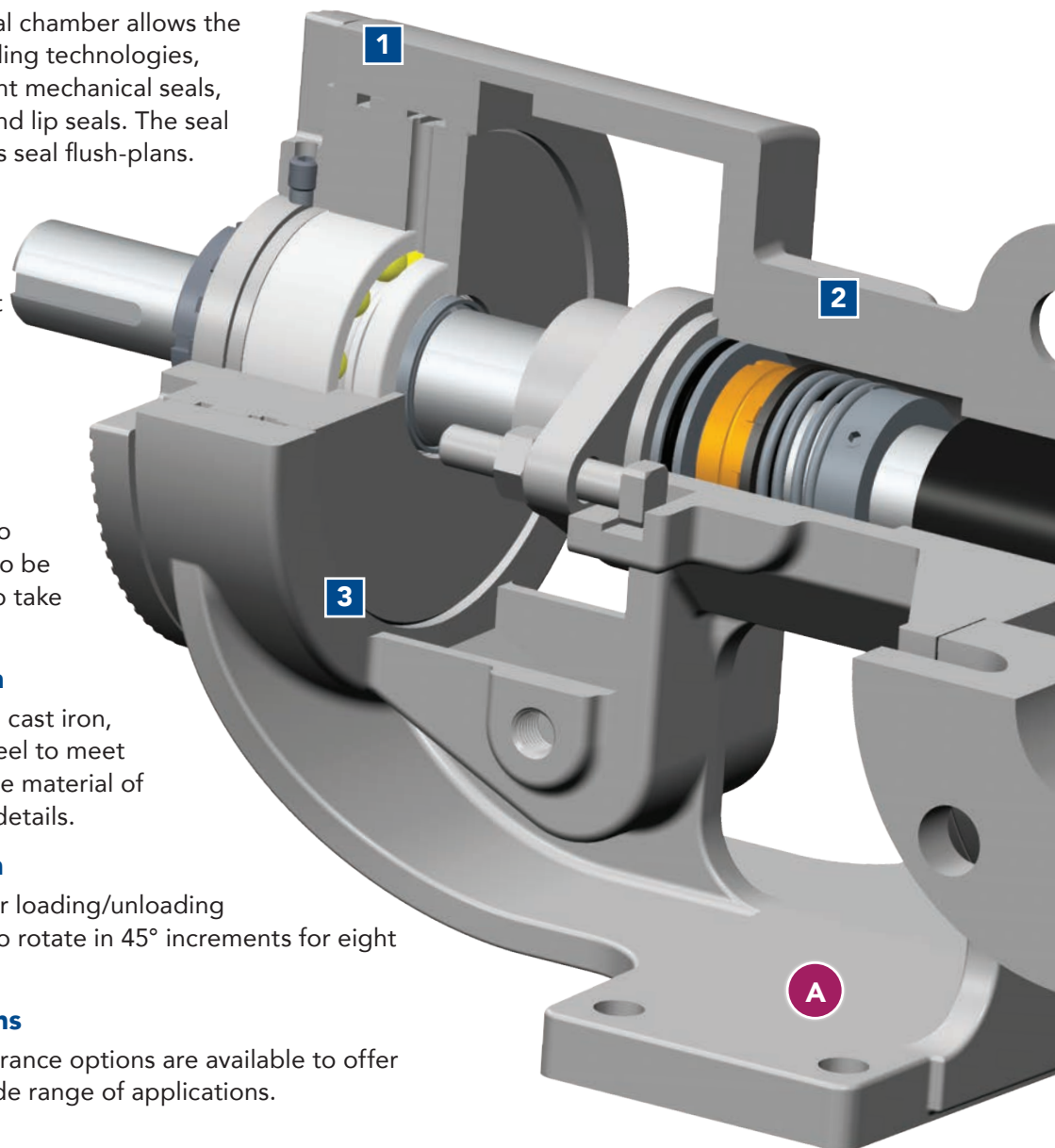



Jacketed Pumps

Jacketing for steam, hot oil, or water to maintain critical process temperature. The following components offer jacketing:

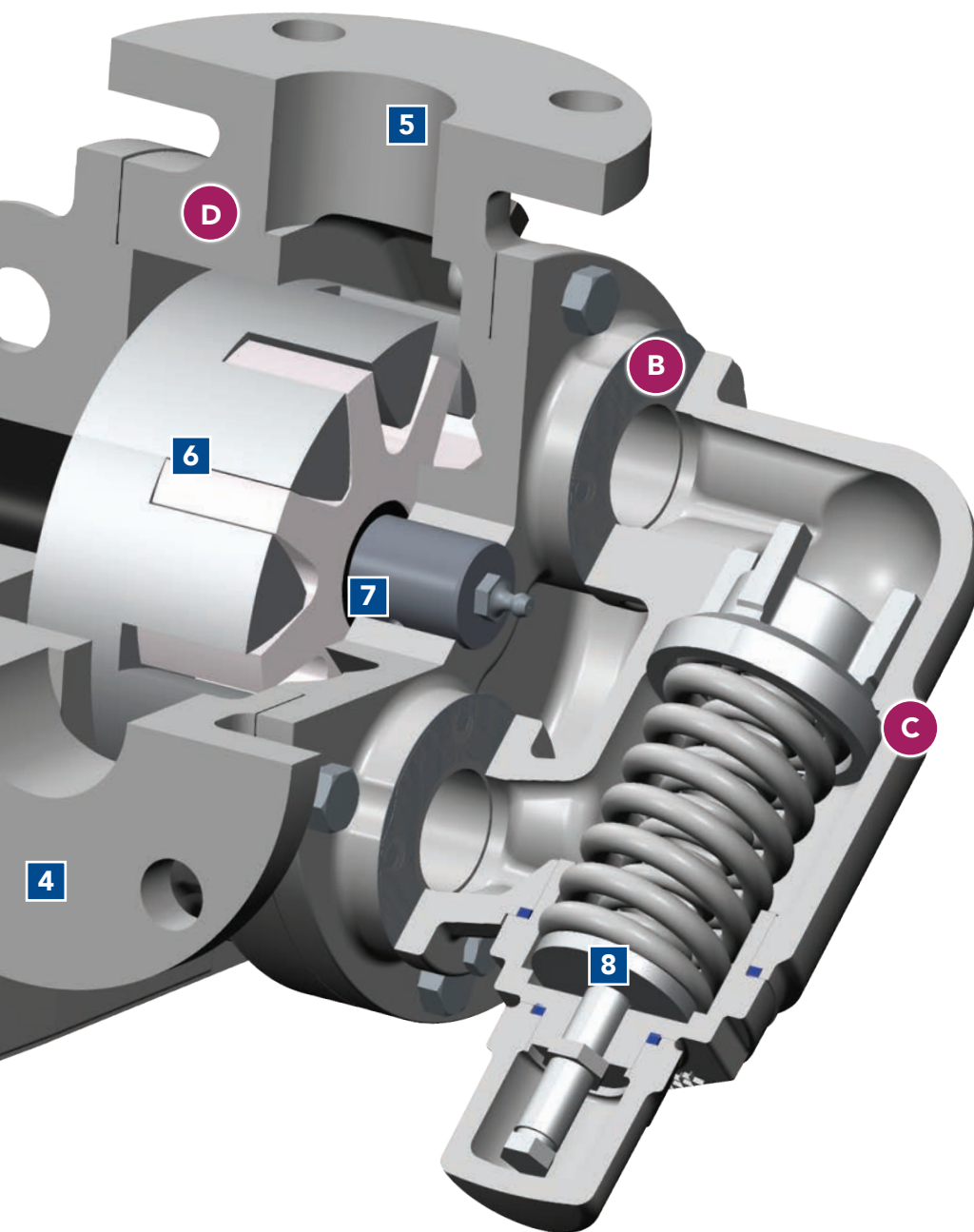

- A Bracket**
Heavy duty one piece cast bracket with seal between bearings to maximize bearing life. Available with jacketing in cast iron construction.
- B Head**
Jacketed head is configurable with or without a jacketed valve in cast iron construction.
- C Relief Valve**
Valve bodies available with jacketing in cast iron.
- D Case**
Optional case jacketing available for 55 and 133 sizes provides non-wearing lifetime protection for radial and thrust bearings.*

** Jacketed case option only available for 55 and 133 sizes.*

Applications

G Series Pumps are excellent for transferring fluids with a wide range of viscosities where consistent, non-pulsating flow is required. With only two moving parts, the pump operates equally well in both clockwise and counterclockwise directions. The pump casing can be repositioned to allow for multiple inlet and discharge positions for ultimate flexibility. The G Series Pump is also offered with multiple internal clearance options and single-point end-clearance adjustment to maximize efficiency and pump life based on your application's viscosity, temperature and fluid characteristics.

- Adhesives
- Biofuels
- Bitumen products
- Chemicals
- Crude oil and fuel oils
- Edible fats and oils
- Equipment lubricants
- Food processing
- Heat-transfer fluids
- Lube oils and greases
- Molten sulfur
- Paint and coatings
- Petrochemicals and additives
- Polyols
- Polyurethane
- Pigments and dyes
- Resins
- Soap and detergents
- Sugars and sweeteners
- Surfactants
- Polymers

Product Configurations

Porting

- Right Angle (90°)
- Opposite (180°) (G1 / G2-222)
- NPT / BSP
- ANSI Flanged

Sealing

- Packing
- Component Mechanical Seal
- Cartridge Mechanical Seal
- Cartridge Triple Lip Seal

Mounting

- Foot Mount

Materials of Construction

- Cast Iron
- Carbon Steel
- Stainless Steel

Jacketing

- Cast Iron Only
- G2-55, G2-69, G2-82, G2-133, G2-222
- Components - Bracket, Head, Relief Valve, Case (G2-55, G2-133 only)

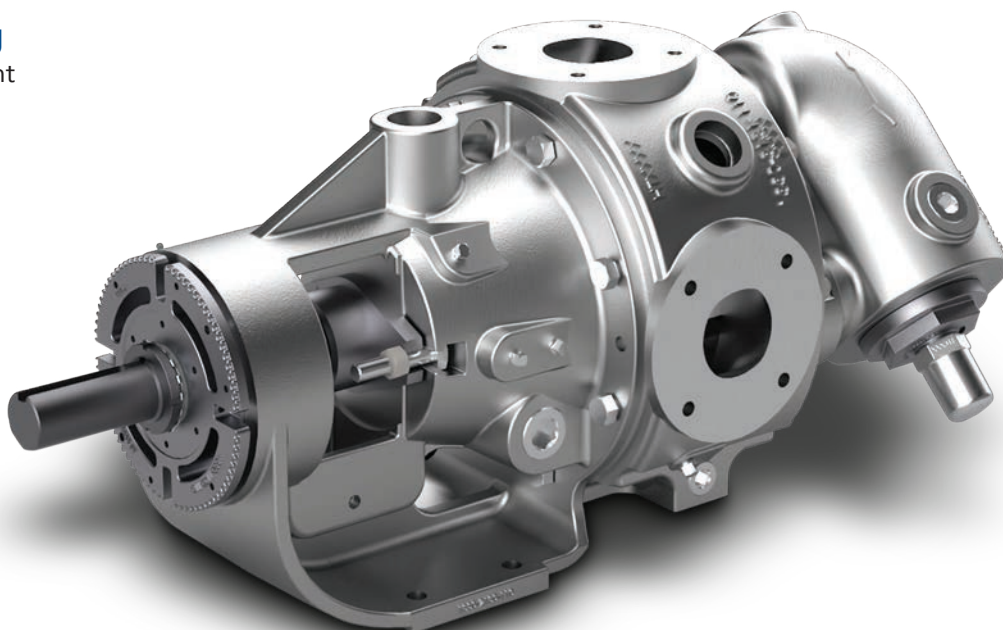

Blackmer® G Series | Technical Data

Port Sizes Available

G1 = Non-Jacketed Pump
G2= Jacketed Pump



MODEL	Standard Non-Jacketed (G1) CAST IRON PORT SIZES ²		Jacketed (G2) CAST IRON PORT SIZES ²		Standard Non-Jacketed (G1) CARBON STEEL PORT SIZES ¹		Standard Non-Jacketed (G1) STAINLESS STEEL PORT SIZES ¹	
	THREADED	FLANGED	THREADED	FLANGED	THREADED	FLANGED	THREADED	FLANGED
G1-2 G1-4	1-1/2" NPT	N/A	N/A	N/A	N/A	1-1/2" ANSI	N/A	1-1/2" ANSI
G1-24 G1-32	2" NPT	N/A	N/A	N/A	N/A	2" ANSI	N/A	2" ANSI
G1-55 / G2-55	2" NPT	2-1/2" ANSI	2" NPT	2-1/2" ANSI	N/A	2-1/2" ANSI	N/A	2-1/2" ANSI
G1-69 / G2-69 G1-82 / G2-82	N/A	3" ANSI	N/A	3" ANSI	N/A	3" ANSI	N/A	3" ANSI
G1-133 / G2-133	N/A	4" ANSI	N/A	4" ANSI	N/A	4" ANSI	N/A	4" ANSI
G1-222 / G2-222	N/A	6" ANSI 180°	N/A	6" ANSI 180°	N/A	6" ANSI 180°	N/A	6" ANSI 180°

(1) Flanged connections meet Class 150# ANSI

(2) Flanged connections meet Class 125# ANSI

(3) Jacketed bracket, head, and valve available in 55-133 sizes; 90° ANSI case optional for 55 and 133 sizes only.

Pump Selection Performance Criteria

Model	Nominal Pump Rating		Max. Discharge Pressure		Max. Temperature		Nominal Pump Rating		Max. Discharge Pressure		Max. Temperature	
	RPM	GPM (m³/h)	PSIG (bar)	Fahrenheit (Celsius)	RPM	GPM (m³/h)	PSIG (bar)	Fahrenheit (Celsius)	RPM	GPM (m³/h)	PSIG (bar)	Fahrenheit (Celsius)
	Cast Iron				Carbon Steel				Stainless Steel			
G1-2	1,750	15 (3.4)	200 (13.8) >20 cSt	650° (343°)	1,750	15 (3.4)	200 (13.8) >20 cSt	650° (343°)	1,150	10 (2.3)	150 (10.3) >550 cSt	500° (260°)
G1-4	1,750	30 (6.8)	200 (13.8) >20 cSt	650° (343°)	1,750	30 (6.8)	200 (13.8) >20 cSt	650° (343°)	1,150	20 (4.5)	150 (10.3) >550 cSt	500° (260°)
G1-24	780	75 (17.0)	200 (13.8) >20 cSt	650° (343°)	780	75 (17.0)	200 (13.8) >20 cSt	650° (343°)	520	50 (11.4)	150 (10.3) >550 cSt	500° (260°)
G1-32	780	100 (22.7)	200 (13.8) >20 cSt	650° (343°)	780	100 (22.7)	200 (13.8) >20 cSt	650° (343°)	520	65 (14.8)	150 (10.3) >550 cSt	500° (260°)
G1-55 / G2-55	640	135 (30.7)	200 (13.8) >20 cSt	650° (343°)	640	135 (30.7)	200 (13.8) >20 cSt	650° (343°)	420	90 (20.4)	150 (10.3) >550 cSt	500° (260°)
G1-69 / G2-69	520	140 (31.8)	200 (13.8) >20 cSt	650° (343°)	520	140 (31.8)	200 (13.8) >20 cSt	650° (343°)	420	110 (25.0)	150 (10.3) >550 cSt	500° (260°)
G1-82 / G2-82	640	200 (45.4)	200 (13.8) >165 cSt	500° (260°)	640	200 (45.4)	200 (13.8) >165 cSt	500° (260°)	520	160 (36.3)	125 (8.6) >550 cSt	500° (260°)
G1-133 / G2-133	520	300 (68.1)	200 (13.8) >165 cSt	500° (260°)	520	300 (68.1)	200 (13.8) >165 cSt	500° (260°)	350	200 (45.4)	125 (8.6) >25 cSt	500° (260°)
G1-222 / G2-222	520	500 (113.6)	200 (13.8) >165 cSt	500° (260°)	520	500 (113.6)	200 (13.8) >165 cSt	500° (260°)	350	320 (72.7)	125 (8.6) >25 cSt	500° (260°)

(1) Maximum pressure listed reflects maximum differential pressure and maximum allowable working pressure.

(2) Values listed in table are nominal and for reference only. To ensure proper pump selection, always refer to Blackmer Select.

(3) Carbon Steel and Stainless Steel models are only available for G Series non-jacketed pumps

Materials of Construction

Description	Part	Cast Iron	Carbon Steel	Stainless Steel	
Pressure Containing	Case	Cast Iron, ASTM A48 Class 35B	Carbon Steel, ASTM A216 Grade WCB	Stainless Steel, ASTM A743 Grade CF8M	
	Head	Cast Iron, ASTM A48 Class 35B	Carbon Steel, ASTM A216 Grade WCB	Stainless Steel, ASTM A743 Grade CF8M	
	Bracket	Cast Iron, ASTM A48 Class 35B	Carbon Steel, ASTM A216 Grade WCB	Stainless Steel, ASTM A743 Grade CF8M	
	Pressure Relief Valve	Cast Iron, ASTM A48 Class 35B	Carbon Steel, ASTM A216 Grade WCB	Stainless Steel, ASTM A743 Grade CF8M	
Product Contact	Idler Gear	Cast Iron, ASTM A48 Class 35B ¹		Stainless Steel, ASTM A564 Type 630 (17-4PH) ⁵	
	Rotor	Standard	Cast Iron, ASTM A48 Class 35B ^{2,4}		Stainless Steel, ASTM A564 Type 630 (17-4PH) ⁵
		Steel Fitted	Carbon Steel, ASTM A311 Grade 1045 Class A ^{3,4}		N/A
	Rotor Shaft	Steel, ASTM A311 Grade 1045		Stainless Steel, ASTM A276 Grade 316	
	Idler Pin	Alloy Steel, Hardened		Stainless Steel, Hardened	
	Idler Bushing	Carbon Graphite, Bronze, Tungsten Carbide		Carbon Graphite, Tungsten Carbide	
	Bracket Bushing	Carbon Graphite, Bronze, Tungsten Carbide		Carbon Graphite, Tungsten Carbide	
Non-Product Contact	Bearing Housing	Cast Iron, ASTM A48 Class 35B			

¹ Cast iron and carbon steel G1-133 and G1-222 come standard with ductile iron idler ASTM A536 Grade 80-55-06

² Cast iron and carbon steel G1-32 come standard with ductile Iron rotor ASTM A536 Grade 60-40-18

³ Cast iron and carbon steel G1-4 steel fitted come with alloy steel grade 8620 rotor

⁴ Cast iron and carbon steel G1-82, G1-133 and G1-222 standard and steel fitted come with ductile iron rotor ASTM A536 Grade 80-55-06

⁵ Stainless steel G1-82, G1-133 and G1-222 come standard with Nitronic 60, ASTM A276, UNS21800 rotor and idler

Comp Model Cross Reference

BLACKMER G SERIES	BLACKMER E SERIES	VIKING®	TUTHILL®	GORMAN-RUPP®
G1-2	E1-2	H	15	GHS 1-1/2
G1-4	E1-4	HL	30	GHS 1-1/2
G1-24	E1-24	K	120	GHS 2
G1-32	E1-32	KK	130	GHS 2
G1-55 / G2-55	E1-55	L & LQ	200	GHS 2-1/2, 3
G1-69 / G2-69	E1-69	LL	210	GHS 3
G1-82 / G2-82	E1-82	LS	250	GHS 3
G1-133 / G2-133	E1-133	Q	N/A	GHS 4
G1-222 / G2-222	E1-222	QS	550	GHS 6

Viking® is a registered trademark of Viking Pump, Inc., a unit of IDEX Corporation.

Tuthill® is a registered trademark of Tuthill Corporation.

Gorman-Rupp® is a registered trademark of Gorman-Rupp® Company.



PSG Grand Rapids
1809 Century Avenue SW
Grand Rapids, MI 49503-1530
USA
P: +1 (616) 241-1611
info@blackmer.com
blackmer.com



Where Innovation Flows

1902-001_a4 01/22

Authorized PSG® Partner:

Copyright 2022 PSG®, a Dover company