



**INDUSTRY PUMPS
AND EQUIPMENT
CATALOGUE**

www.pcm.eu



FLUID HANDLING EXPERTS IN INDUSTRY

PCM offers versatile, robust and easy to maintain technical pumping solutions, designed to adapt to future needs. We specialise in handling your difficult products and materials: abrasive, fragile, viscous, corrosive, explosive, hot or dense.

LOW LIFE CYCLE COSTS

Our use of Life Cycle Costs (LLC) analysis to find the most cost-effective pumping solutions for your industrial processes assures you savings in production costs, reduced maintenance downtime, and lower energy consumption.

ECO-DESIGNED PUMPS

Today, PCM has unrivalled experience regarding eco-designed pumps. PCM eco-design approach aims to reduce the environmental impact of a solution during all the stages of its life cycle, from suppliers and manufacturing through to decommissioning. In doing so, we enable you to meet your operational and environmental requirements at the same time.

ELASTOMER EXPERT

Elastomers are very unique materials that play a critical role in the operational efficiency of positive displacement pumps. To ensure that our pumps always feature the highest quality and use the most compatible elastomers, we manufacture our own. Over 80 years of experience developing, mixing and producing our own elastomers has given us unparalleled expertise in this domain. We have an extensive database of elastomer formulas and fluid compatibilities.

OUR MARKETS

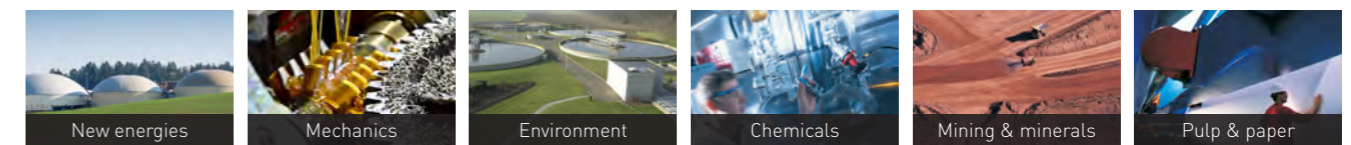

1930
René Moineau invents the Progressing Cavity Pump (PCP).

1970
PCM invests beyond the Progressing Cavity Pump and adds Delasco™ and Precipommes™ to its product range.

2012
PCM launches the EcoMoineau™ C stainless steel progressing cavity pump



1932
René Moineau, in partnership with Robert Bienaimé, founded PCM Pompes



2006
PCM launches the first eco-designed progressing cavity pump, the EcoMoineau™ M



2017
PCM strengthens its Delasco™ peristaltic pump range with the DX Series and its hopper PCP range with the EcoMoineau™ MVA.



PCM ELASTOMER EXPERTISE

From selection to manufacturing, PCM controls the complete process of elastomer production for progressing cavity pumps.



Elastomer selection requires specific knowledge and experience that few companies in the world possess. PCM has gained a vast amount of knowledge and experience over the years and has invested in essential equipment and resources to continuously improve our ability to select, develop, and produce optimal elastomers uniquely suited for our customers' diverse applications.

The hundreds of different fluids PCM customers have to transfer or dose, all bring serious concerns and solutions to find in order for the elastomers used in PCM equipment to guarantee the optimal functional characteristics. These issues to be considered for an elastomer selection are:

- mechanical resistance to abrasion,
- chemical resistance to the pumped fluid,
- desired color,
- regulations compliance and rules,
- optimized lifetime,
- product integrity (structure, turbidity...),
- resistance to cleaning procedures.

The main difficulty is for a given application to find the elastomer that will offer the best behavior between **chemical compatibility** and **fluid abrasivity**, taking into account the other factors such as regulations or other constraints brought by the manufacturing process of our customers.

CHOOSING THE RIGHT ELASTOMER

PCM has developed tens of different elastomers, with different raw materials and different manufacturing recipes, thus offering a large choice of solutions for almost every application.

Polyisoprene (IR)	Chloroprene (CR)	Butadiene acrylonitrile (NBR)	Ethylene - Propylene - Diene (EPDM)	Fluor rubber (FPM/FKM)
Abrasion Neutral pH	Medium abrasion Low corrosion	Greasy substance	Medium corrosion	High corrosion
Mineral suspensions, chalk, clay, calcium carbonate	Calcium chloride, disodium phosphate, pig feed preparation, starch	Hydrocarbons Step sludges	Starch, other industrial products	Solvents

Corrosion -
Abrasion +++

Corrosion +++
Abrasion -

A key design characteristic of a Progressing Cavity Pump is the tolerance between the stator and the rotor. Stator dimensions and characteristics are ensured by strict control of:

- chemicals composition (10 to 20 different components),
- casing dimensions,
- manufacturing process variation (temperatures, injection pressure, curing...)



- NBR
- EPDM
- NR / IR
- CR
- FKM

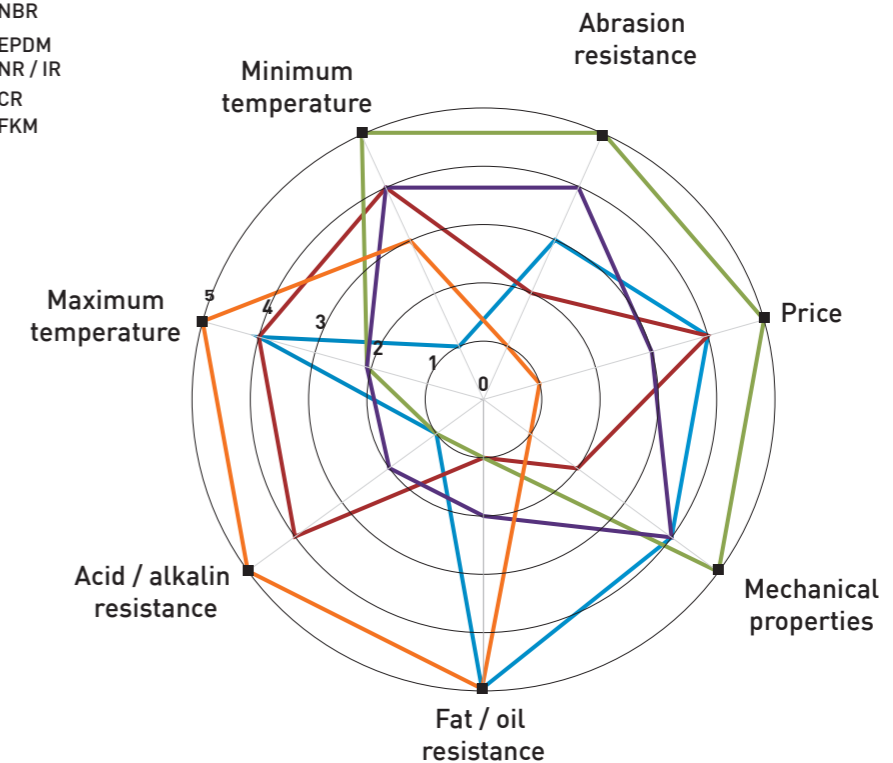

ELASTOMERS TESTING

From laboratory testing equipment to large mixers, injection presses and vulcanization ovens, PCM has all the necessary equipment and knowledge within its premises to assure perfect control of its elastomer selection and manufacturing.

Testing & characterization equipment:

- mechanical tests (static, dynamic, compression, bonding)
- tribology (abrasion, friction)
- chemical tests (swelling tests, volume and hardness variation, thermal analysis, infra-red spectroscopy)

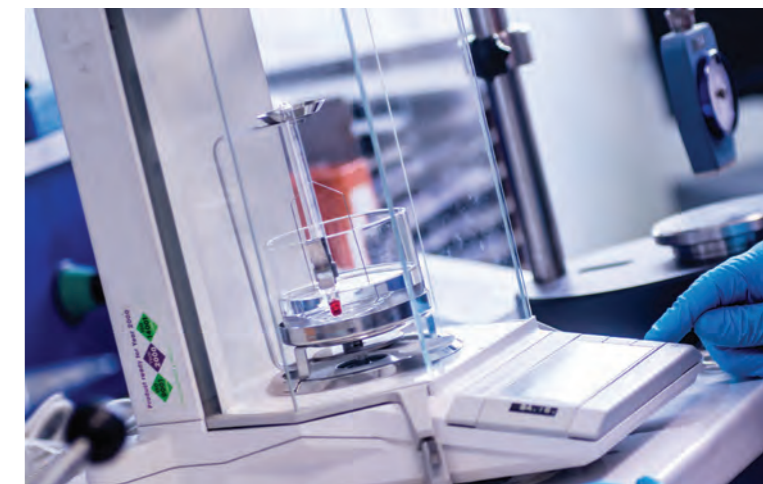

TABLE OF CONTENT

PCM MARKETS & APPLICATIONS	8
• Environment	10
• Mining & minerals	12
• Pulp & paper	14
• New energies	16
• Chemicals	18
• Mechanical engineering	20
PCM TECHNOLOGIES	22
PCM Moineau™ progressing cavity pumps	24
• PCM EcoMoineau™ M	26
• PCM EcoMoineau™ C	30
• PCM EcoMoineau™ with floating stator	34
• PCM EcoMoineau™ MSH - MVA - MVA FF	38
PCM Delasco™ peristaltic pumps	44
• PCM DX-Z-PMA Series	46
PCM Lagoa dosing pumps	52
• PCM Lagoa	54
PCM grinders	58
• PCM X-Guard	60
• PCM Macerator	62
PCM SERVICES	64



PCM MARKETS & APPLICATIONS

PCM serves six highly demanding industrial markets. While all of them share similar requirements in terms of reliability, cost effectiveness and productivity, each has special needs that PCM meets with perfectly adapted pumping systems.

› ENVIRONMENT

The choice of competitiveness

One of the most important challenges in environmental protection is the cost-effective treatment and handling of municipal and industrial waste water. PCM pumps are used to handle industrial and municipal waste water and sewage, dewatered sludge and to meter chemical additives.

› MINING AND MINERALS

The choice of robustness

Abrasiveness is the number one challenge in the mineral industry. Downtime caused by equipment failure can bring an entire mine or production facility to a halt. Consequently, robustness, ease of maintenance and spare part delivery times are of the utmost importance.

› PULP AND PAPER

The choice of smooth productivity

The paper industry is one of the most demanding sectors in terms of productivity, water treatment and dosing. Most production facilities operate non-stop, and any downtime can be costly. In addition, pulp and paper plants use incredible quantities of water, which they must manage and treat in accordance with strict regulations.

› NEW ENERGIES

The choice of sustainability

To meet their promises of sustainability, new energies must combine environmental responsibility with real-world economics. To reach economically viable production levels, their industrial processes require pump systems capable of handling a wide range of fluids and solids accurately and reliably.

› CHEMICALS

The choice of compatibility

Product compatibility and versatility are what the chemical industry looks for in pumps. Manufacturers of special chemicals require pumps capable of handling fluids with fragile composition and complex rheology.

› MECHANICAL ENGINEERING

The choice of versatility

Light and heavy industries require versatile pump systems that can be easily integrated into their production chains, whether upstream during manufacturing or downstream during waste processing. Pumps need to be reliable, robust and capable of handling a wide range of emulsions, metal particles and corrosive materials.



ENVIRONMENT

Clear choice for treating liquid waste

Pumping systems play a crucial role in the environmental industry, ensuring that industrial and municipal wastewater is handled economically and reliably.

PCM pumping equipment is available for a wide range of key applications in the treatment of wastewater. **PCM pumps are designed to offer the robust performance required for transferring wastewater, dewatered sludge, and metering chemicals** such as lime slurry, ferric chloride or polymer in traditional wastewater treatment plants. All steps of water treatment processes are efficiently supported by PCM equipment, from pre-treatment to final sludge evacuation.

We also provide solutions for other water treatment applications, such as flue gas clean-up, landfill leachate, recovering hydrocarbon and performing ground remediation.

SOME CHALLENGES TAKEN BY PCM



Challenge:

A major French company that collects and treats industrial and residential waste water uses lobe pumps to feed filter presses for sludge dewatering. The client complained about the low level of dryness of the final waste product.

PCM solution:

PCM progressing cavity pumps have a much higher capacity for flowrate control and for pressure delivery than what can be provided by lobe pumps. For this reason, replacing them with 50M18S or 13M24S PCM progressive cavity pumps with 3 or 4 stages, the client was able to quickly see the drop in the water content of the final product at the outlet of the filter press as well as the decrease of the time needed to feed them.



Challenge:

A major manufacturer of sodium carbonates and bicarbonates must review its waste rock disposal facility following the extension of its salt extraction zone. The new discharge zone is now more than 6 km away from the storage tanks and requires a pumping system capable of controlling more than 290 psi of pressure due to pressure drop in the pipes and the viscosity of the sludge discharged.

PCM Solution:

PCM offers a 5-stage Moineau™ pump, capable of delivering a flow rate of 352 gpm at a pressure of 435 psi equipped with a cast iron body, a 316L stainless steel rotor with a 100µm chrome coating, a synthetic polyisoprene stator resistant to high abrasiveness and a double mechanical seal lubricated with glycol in order to withstand strong possible heating. This pump runs 24 hours a day, 7 days a week, and cannot afford long period of downtime. The customer also has an identical emergency pump and all first emergency spare parts necessary for the rapid restoration of its pump.

PCM OFFER FOR ENVIRONMENTAL APPLICATIONS

	PCM EcoMoineau™ M	PCM EcoMoineau™ C	PCM EcoMoineau™ with floating stator	PCM EcoMoineau™ MVA	PCM Delasco™ DX	PCM Delasco™ Z	PCM Delasco™ PMA	PCM Lagoa	PCM Grinders
Municipal waste water treatment	●		●		●				●
Industrial waste water treatment	●	●	●		●				●
Flocculant/concentrated polymer dosing		●			●		●	●	
Flocculant/diluted polymer dosing	●		●					●	
Chemical dosing	●	●	●		●	●	●	●	
Filter-press feeding	●	●			●				



MINING AND MINERALS

Bringing flawless solutions to tough environments

The harsh working environments and tough pumping conditions typical of quarrying, mining, ceramic or construction can quickly generate unscheduled downtimes and costly repairs.

Centrifugal pumps with inevitable high speeds are detrimental to fragile polymers, demand enormous horsepower as well as costly external flush plans and fail rapidly when moving the abrasive fluids traditionally found in mining processes. PCM pumps guarantee a **constant flow regardless of back pressure, viscosity or solids content variations**. Therefore they are very efficient in supporting processes where transfer and dosing are crucial, from **precious metal recovery to tailings treatment, including explosive preparations**.

PCM range of positive displacement pumps offers the best-suited technologies to meet your demand for constant productivity while keeping costs under control.

SOME CHALLENGES TAKEN BY PCM



Challenge:

A French quarry producing gravel, rolled and crushed from a silico-limestone deposit uses a progressing cavity pump to ensure the transfer of its mineral sludge at the outlet of its settling tank. This quarry finds that it must replace too often the wearing parts of this pump (stator, seals and sheaths) and is asking PCM to find a more economically viable solution.

PCM solution:

PCM selects a 120M12S progressing cavity pump equipped with a synthetic polyisoprene (IR) stator and a rotor coated with a 400µm thick chromium plating, which guarantees optimum abrasion resistance. We accompany this selection with the possibility for this new customer to test it and thus commit to the purchase of this pump only after a probationary period allowing him to measure concretely the gains that this new pump will provide it throughout its extended lifespan. Three months after the first pump lapse in his quarry, and anticipating an annual gain of some € 5,000, thanks to the spacing of the maintenance periods, the customer acquired the PCM pump.

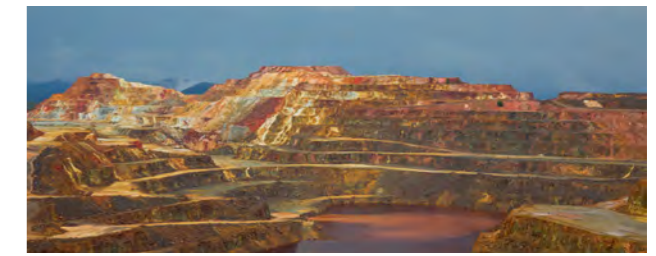

Challenge:

One of the world's largest producers of lime and gypsum stones has to transfer lime slurries from a thickener to a heat exchanger at a regulated flow rate of 110 gpm, at a pressure of 116 psi. The transferred sludge can contain up to 20% solids with possible 40mm particles. This quarry is accustomed to using centrifugal pumps, but the operating point of the pump used for the transfer in question proves to deliver too higher flowrate for the heat exchanger and requires a motorization of very high power (174 hp), extremely energy-consuming and noisy.

PCM solution:

The extended operating range of the progressing cavity pumps allows PCM to recommend a 120M12S pump with a motor of only 24.8 hp instead of the centrifugal pump used. The PCM pump consumes 7 times less energy than the centrifugal pump, requires much less maintenance, allows greater regulation of the flow obtained and in particular allowed the quarry to get rid of its installation that was controlling the overflow of its centrifugal pump (removal of several tens of meters of piping and a tank of high capacity). The customer also appreciates the significant noise reduction of his new pump...

PCM OFFER FOR MINING APPLICATIONS

	PCM EcoMoineau™ M	PCM EcoMoineau™ C	PCM EcoMoineau™ with floating stator	PCM EcoMoineau™ MVA	PCM Delasco™ DX	PCM Delasco™ Z	PCM Delasco™ PMA	PCM Lagoa	PCM Grinders
Flocculant dosing	●	●	●		●			●	
Filter-press feeding	●	●			●	●			
Chemicals dosing		●	●		●			●	
Mortar grout transfer	●			●	●	●			
Sludge dewatering	●	●		●	●	●			
Explosive products dosing		●	●						



PULP AND PAPER

Delivering business-critical strength

No industry is as demanding as paper and pulp manufacturing when it comes to reliability and cost efficiency.

PCM volumetric pumps, with their **very high level of reliability and efficiency**, are the best-in-class solutions to cope with **stock and starch preparation, paper coating and sludge treatment**. All these processes require equipment that resists to both very abrasive products and corrosive ones, and that may require **high suction capabilities, gentle handling and chemical compatibility**.

When you need a single source to reduce the Life Cycle Cost of your pumping equipment, PCM is the partner of choice, from components to pumps, including services and expertise.

SOME CHALLENGES TAKEN BY PCM



Challenge:

A paper mill specialized in the manufacturing of high-end cigarette papers is developing a very airy paper pulp that is difficult to transfer by traditional centrifugal pump techniques. This plant is looking for pumps capable of transferring such a paste whose texture and rheology evolve throughout the various stages of its manufacturing process, at a minimum flow rate of 396 gpm. In addition, this paste does not tolerate any trace of ferric ions and cannot be brought into contact with conventional materials.

PCM solution:

PCM EcoMoineau™ C high capacity pumps have all the qualities required by this paper mill. The extreme aeration of their pastes does not represent an obstacle to their pumping and their stainless steel configuration makes them fully compatible with the implementation process. A pilot unit is put in place, proving that the selected equipment is fully compliant with the specifications and makes possible an upcoming industrial installation.



Challenge:

One of Europe's largest thermal paper coating sites uses more than 150 pumps of various technologies. This company has problems with the reliability and lifespan of its eccentric disc pumps when pumping kaolin, a highly abrasive product. Forced to replace the stainless steel discs of these pumps every 2 months, they are looking for a more competitive alternative solution and subject to less maintenance operations.

PCM solution:

PCM offers the EcoMoineau™ C stainless steel pumps to best withstand the corrosiveness of pumped products. The selection consists of the combination of polychloroprene (CR) stators, offering a very good resistance to abrasive products while guaranteeing good resistance to chemical attack, and stainless steel rotors coated with a 400µm chromium layer to improve the hardness. Some pumps, those most stressed in abrasion, are configured with ceramic rotors. Mechanical seals are back-to-back cartridge design. These pumps are now systematically installed by this customer when he has to pump and dose highly abrasive and corrosive products.

PCM OFFER FOR PAPER APPLICATIONS

	PCM EcoMoineau™ M	PCM EcoMoineau™ C	PCM EcoMoineau™ with floating stator	PCM EcoMoineau™ MVA	PCM Delasco™ DX	PCM Delasco™ Z	PCM Delasco™ PMA	PCM Lagoa	PCM Grinders
Pulp preparation	●	●	●						
Coating preparation		●			●			●	
Glue and pigmentation preparation	●	●	●		●	●	●		
Chemicals dosing		●	●		●		●	●	
Waste water treatment	●	●	●	●	●				
Starch transfer	●	●	●		●	●	●		



NEW ENERGIES

The choice of sustainability

To meet their promises of sustainability, the new energies market must combine environmental responsibility with real-world economics. Industrial processes require pump systems capable of **handling a wide range of fluids and solids accurately and reliably, while keeping costs under control.**

PCM volumetric pumps, with their wide range of materials and options, perfectly meet these miscellaneous demanding processes. Because they can **transfer products without shear and offer resistance to the aggressive chemical and mechanical constraints** and have the capability to pump **fluids with large solid contents**, they are very efficient solutions for **biomass treatment, biofuel preparation, flue gas desulfurization or coal water mixtures.**

SOME CHALLENGES TAKEN BY PCM



Challenge:

A dry methanisation unit wishes to manage the recirculation of its digestates in its digester as well as the return to a post-digester after dilution with water in order to allow the recovery of additional gas and thus increase the overall profitability of the installation. This unit also wants to feed a phase separator to manufacture liquid and solid spreading products.

PCM solution:

PCM, in connection with the consulting firm specializing in the design of anaerobic digestion plants, proposes the use of a single 120M12S Moineau™ pump equipped with a frequency converter to ensure the 3 desired functions (recirculation of the digestate / transfer to post-digester / send to phase separator), by associating this pump with a set of valves and instrumentations controlled by the integrated supervision system of the whole installation.



Challenge:

In order to protect its circulation pumps supplying a leachate dispersion unit, taken from the digester bottoms and sprinkled on the surface of the organic substrate, a methane producer wishes to have a grinder that will reduce the solid waste like branches or rags to small particles.

PCM solution:

The PCM X-Guard grinder, which is both good in grinding and easy to install and maintain, allows the reduction of solids in particles not exceeding 5 to 6 mm, and thus can be easily pumped and if necessary discarded by conventional load collectors.

PCM OFFER FOR NEW ENERGY APPLICATIONS

	PCM EcoMoineau™ M	PCM EcoMoineau™ C	PCM EcoMoineau™ with floating stator	PCM EcoMoineau™ MVA	PCM Delasco™ DX	PCM Delasco™ Z	PCM Delasco™ PMA	PCM Lagoa	PCM Grinders
Manure transfer	●			●	●				●
Biomass digester feeding	●			●	●				●
Biomass circulation	●			●	●				
Chemicals dosing		●	●		●	●	●	●	
Polymers dosing	●	●	●			●	●	●	



CHEMICALS

Compatibility and versatility

Product compatibility and versatility are what the chemical industry looks for in pumping solutions. Manufacturers of chemicals require pumps capable of handling fluids with fragile composition and complex rheology.

PCM offers pumping and metering solutions for the chemical industries where **safety is the primary concern**. Users are not only looking for an **efficient and cost effective equipment**, they also need to be convinced that in case of failure any potential leakage will be contained and that the **pump will be easy to operate and maintain**.

There is no industry more diversified than the chemicals industry, where **aggressive acids, highly flammable or explosive products**, require material compatibility and thermal control. PCM equipment is designed to perfectly meet these high-level requirements.

SOME CHALLENGES TAKEN BY PCM



Challenge:

One of the world leaders in the manufacture of synthetic gemstones has to transfer Alum powder, a highly abrasive product, and initially opts for a peristaltic pump. After a few weeks of use, he cannot tolerate the need to replace the tube of this pump every 2 days, not benefiting from his supplier of a sufficiently resistant material.

PCM solution:

An engineering firm advises this company to contact PCM. After the analysis of the situation, we recommend to change the pump technology, knowing that the mechanical constraints of the atomization process of this manufacturer of crystals would not be compatible with the use of peristaltic pumps. A 3C24S PCM progressing cavity pump with a synthetic polyisoprene (IR) stator has been installed and 6 months after it was started, only 2 maintenance operations were necessary.



Challenge:

A chemical production center in the East of France has just acquired 3 lobe pumps but after only a few days of commissioning, the managers of this center realize that these pumps are not working properly; they do not provide the theoretically promised flowrate at the required service pressure. The chemical formulation unit must start within 2 weeks and engineers are working on finding a solution.

PCM solution:

PCM offers small EcoMoineau™ C metering pumps (05C12S), which are available, including engines, under extremely short lead times. These pumps perfectly meet the desired requirements, especially in terms of guaranteeing the delivered flow rate which must remain constant even when the pressure and the viscosity of the product vary over a clearly identified range. The pumps in question have been delivered in 15 days and the formulation unit can start on time...

PCM CHEMICAL APPLICATIONS

	PCM EcoMoineau™ M	PCM EcoMoineau™ C	PCM EcoMoineau™ with floating stator	PCM EcoMoineau™ MVA	PCM Delasco™ DX	PCM Delasco™ Z	PCM Delasco™ PMA	PCM Lagoa	PCM Grinders
Polymers production	●		●		●		●	●	
Acids dosing		●	●			●	●	●	
Reagents / additives treatment		●	●			●	●	●	
Phytosanitary products handling		●	●		●				
Foam production	●	●	●		●				
Glue dosing	●	●	●		●		●	●	
Effluent treatment	●			●	●	●			



MECHANICAL ENGINEERING

Solid polyvalency

Light and heavy mechanical industries require **versatile pump systems** that can be easily integrated into their production chains, **whether upstream for manufacturing or downstream for waste processing. Pumps need to be reliable, robust and capable of handling a wide range of emulsions, metal particles and corrosive materials.**

Surface treatments, painting and pre-treatment applications, as well as **waste processing** are applications requiring a high level of modularity of the design of the pumps. PCM offers solutions that perfectly match these expectations and that resist to aggressive media and are easy to clean. All key benefits needed by this industry.

SOME CHALLENGES TAKEN BY PCM



Challenge:

A manufacturer of composite materials for the automotive and aerospace industries is developing a revolutionary material that allows for the most flexible shaping, soundproofing and thermal insulation, at a production cost never equaled. One of the raw materials used for the production of this material is a very low density powder, of the microsphere type, the dosage of which does not tolerate any incorporation of air. The diaphragm pumps traditionally used by this company are reaching their limits and can not ensure a sufficiently precise mass distribution.

PCM solution:

PCM Delasco™ Peristaltic Pumps meet all the requirements of this company. They slightly compress the powders during their pumping, giving them a flow property close to a very low viscosity liquid without altering the primary characteristics. The desired industrial flow rate of 11 gpm at a pressure of less than 44 psi directs the choice to a PCM Delasco™ Z series peristaltic pump.



Challenge:

A manufacturer of mixing and stirring equipment offers its clients turnkey skids including agitator tanks, mixers, control panels and pumps for filling and emptying these skids. Their specialty is the mixing of complex, often highly viscous products, and the required pumps must be capable of transferring and dosing fluids under high pressure stresses while offering the lowest possible dimensional characteristics for easy integration into mixing skids.

PCM solution:

PCM provides pumps combining the two qualities required by this customer thanks to its progressing cavity pumps with floating stator (MF). In particular the 4M12F pump allows pumping at a flow rate of more than 8,8 gpm at a pressure of 116 psi, and does not exceed an overall length of 25.2" when equipped with a motor of 1 HP.

PCM OFFER FOR MECHANICAL APPLICATIONS

	PCM EcoMoineau™ M	PCM EcoMoineau™ C	PCM EcoMoineau™ with floating stator	PCM EcoMoineau™ MVA	PCM Delasco™ DX	PCM Delasco™ Z	PCM Delasco™ PMA	PCM Lagoa	PCM Grinders
Waste oil treatment	●				●				
Paint / varnishes / cataphoresis treatment		●	●		●				
Polymers transfer	●	●	●				●	●	
Chemicals dosing		●	●			●	●	●	
Galvanizing baths handling	●	●			●	●			
Degreasing / pickling baths handling	●	●			●	●			
Engine coolant treatment	●	●	●						
Oil transfer	●	●	●		●	●	●		



PCM TECHNOLOGIES

PCM provides a wide range of positive displacement pumps, designed to meet your needs whatever industry you are working in.

▶ PROGRESSING CAVITY PUMPS: PCM MOINEAU™

From the name of the inventor and PCM co-founder: René Moineau

PCM progressing cavity pumps are those originally designed by René Moineau to ensure the transfer of very viscous and fragile fluids under extreme conditions of flowrate and pressure. Our pumps offer very low shear operations and are pulsation free. They are very versatile and are especially suited to processes where regularity and accuracy are requested.



Range of PCM Moineau™ progressing cavity pumps

- PCM EcoMoineau™ M
- PCM EcoMoineau™ C
- PCM EcoMoineau™ with floating stator
- PCM EcoMoineau™ MVA/MVA FF

▶ PERISTALTIC PUMPS: PCM DELASCO™

The ideal choice to reduce maintenance costs

Our pumps use the peristaltic principle, whereby the deformation and compression of a soft elastomer hose allows fluid to be passed through the system. They are robust and easy to maintain, meaning they can be used in a wide range of industrial applications. They are particularly suited to abrasive or corrosive fluids.



Range of PCM Delasco™ peristaltic pumps

- PCM DX Series
- PCM Z Series
- PCM PMA Series

▶ DIAPHRAGM PUMPS: PCM LAGOA

Accuracy and reliability: ingredients of a successful dosing

Ideally suited to applications which require accurate dosing (chemical engineering, environmental applications), our diaphragm dosing pumps also offer smooth pumping with a very low shear action.

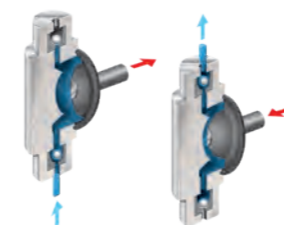

Range of PCM Lagoa diaphragm dosing pumps

- PCM Lagoa

▶ PCM GRINDERS & MACERATORS

The cost effective way to protect your downstream equipment

PCM offers technologies that are well suited to different types of wastes to be grinded and offers a macerator for fibrous string-type materials and a grinder for solid wood, plastic or pebble material.

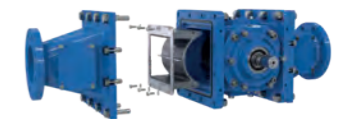

Range of PCM grinders

- PCM X-Guard
- PCM Macerator

PCM MOINEAU™ PROGRESSING CAVITY PUMPS

From the name of the inventor and PCM co-founder: René Moineau

› PRINCIPLE OF MOINEAU™ TECHNOLOGY

A Moineau™ pump consists of a helical rotor turning into a helical stator. When the rotor turns inside the stator, the honeycomb progresses spirally along the axis of the pump without changing either shape or volume. This action transfers the product from the pump suction to the pump discharge without degrading the product. This basic principle of Moineau™ pumps allows a high accuracy of flow and pressure, making these pumps extremely efficient for transferring and dosing the most complex fluids.

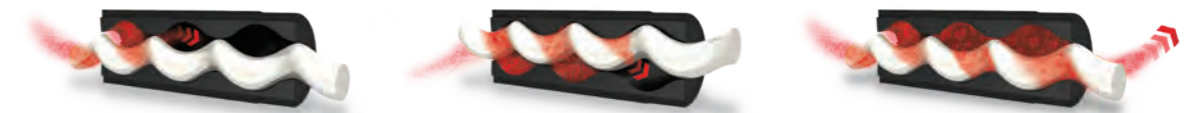

PCM Moineau™ pumps are configurable to perfectly fit to the multiple applications proposed by their users. From the choice of the elastomers of their stator, to the coating of their rotor, through the choice of the types of dynamic seals of their drive, but also many other options, each PCM Moineau™ pump is modular and thus meets all constraints.

› BENEFITS

- Preserves the texture of fragile fluids (no shearing compared with lobe or centrifugal technologies)
- Handles fluids with solids
- High suction capability
- Self-priming
- Constant non-pulsating flow
- Reversible

› RANGE OF PCM PROGRESSING CAVITY PUMPS

- PCM EcoMoineau™ M
- PCM EcoMoineau™ C
- PCM EcoMoineau™ with floating stator
- PCM EcoMoineau™ MVA/MVA FF



PCM ECOMOINEAU™ M

The first eco-designed Progressing Cavity Pump in the market



The PCM EcoMoineau™ M pump is the **most compact Progressing Cavity Pump (PCP) available on the market today**. Its revolutionary design combines the legendary performance and reliability of PCM PCP technology with a highly modular, eco-friendly design.

Because the PCM EcoMoineau™ M pump is more compact than comparable PCP, **it requires less space (only 7 cm / 2.75 inch for the biggest models) for servicing, which speeds up maintenance, reduces civil engineering costs and eases integration systems.**

It complies with the European Energy-using Products (EuP) directive. **Its design uses less raw materials and 10% less power** than previous generation of Moineau™ pumps.

The PCM EcoMoineau™ M pump is made with fewer parts compared to competitors models. This cast iron PCP has a multiple of design features that make installation, operation and servicing easier than ever before.



TECHNICAL PERFORMANCES

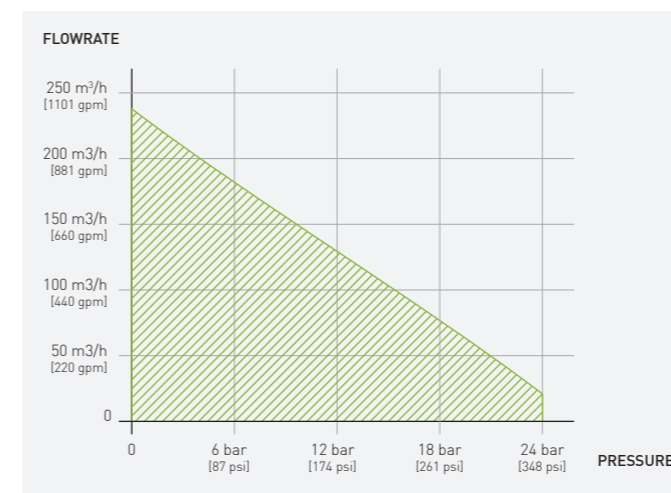

EXAMPLES OF APPLICATIONS

- Sludge drainage (environment)
- Filter-press feeding (mines and quarries)
- Starch transfer (paper)
- Biomass circulation (new energies)
- Polymer production (chemistry)
- Used oil treatment (mechanics)

► PUMP CONSTRUCTION

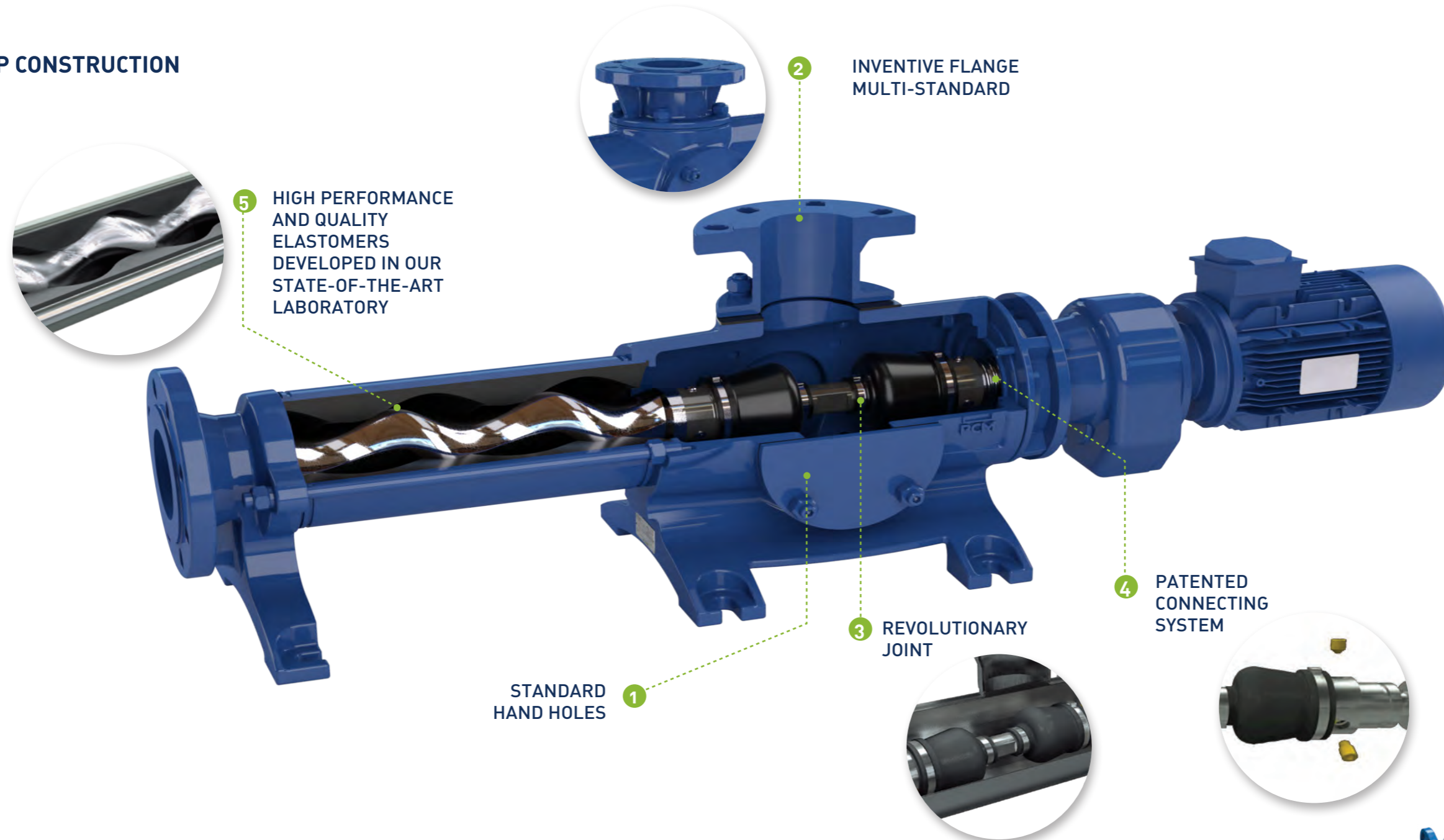

5 HIGH PERFORMANCE AND QUALITY ELASTOMERS DEVELOPED IN OUR STATE-OF-THE-ART LABORATORY

2 INVENTIVE FLANGE MULTI-STANDARD

1 STANDARD HAND HOLES

3 REVOLUTIONARY JOINT

4 PATENTED CONNECTING SYSTEM

► JOINT ASSEMBLY BENEFITS

- **Cost and stock savings:** same joint assembly for all models from the same module
- **Maintenance time saving:** 3 screws only to dismantle the joint. No sheath dismantling, nor usage of grease or oil.
- **Patented connecting system**
- **Durable and robust design:** lifespan increase for non corrosive and non abrasive applications



► PCM ECOMOINEAU™ M RANGE BENEFITS

SPACE SAVING

- Revolutionary joint 80 % shorter than other PCPc on the market
- Revolutionary joint coupling rod length reduced and hardened for long life operation
- Patented connecting system: only 7 cm of clearance required to dismantle the stator of the biggest models

EASY AND QUICK MAINTENANCE

- Patented connecting system with 3 screws only
- Hand holes to ease pump body access, declogging, cleaning and pump operation observing
- Sealing maintenance by just removing the drive from the back

ECO-DESIGN PUMP

- 10% less power consumption compared to most Progressing Cavity Pumps on the market
- Less raw materials

VERSATILE CONSTRUCTION

Integrated construction

- Shortest design
- Fewer parts, no drive shaft
- Self-positioning mechanical seal
- Standard mechanical seals eliminate leaking, tightening and adjustment
- Reduced mechanical seal diameter lowers spare parts costs
- Ideal for non sticky and low abrasive fluids

Monobloc and bearing construction

- Reduced dimensions
- Built-in drip tray
- Versatile configurations (seals and stators)
- Spacer with improved access to the sealing system
- Rubber deflector (protects the drive and bearing therefore reducing maintenance)

Hopper option

- Recovery and transfer of thickened sludges (up to 120 g/l) from dripping table





PCM ECOMOINEAU™ C

The most corrosion resistant Progressing Cavity Pump in the market



Its revolutionary design combines the legendary performance and reliability of **PCM Progressing Cavity Pumps technology** with a highly modular, eco-friendly design. The PCM EcoMoineau™ C pump requires less space for installation which reduces costs and facilitates its integration.

The PCM EcoMoineau™ C pump is **lighter** (less raw materials) and **uses 10% less power** than most progressing cavity pump on the market. The energy

used to manufacture, transport and operate the PCM EcoMoineau™ C pump is therefore optimised.

This PCP is made with fewer parts compared to competitors models. This new stainless steel pump has a **multitude of design features** that make **installation, operation and servicing easier than ever before**.



TECHNICAL PERFORMANCES

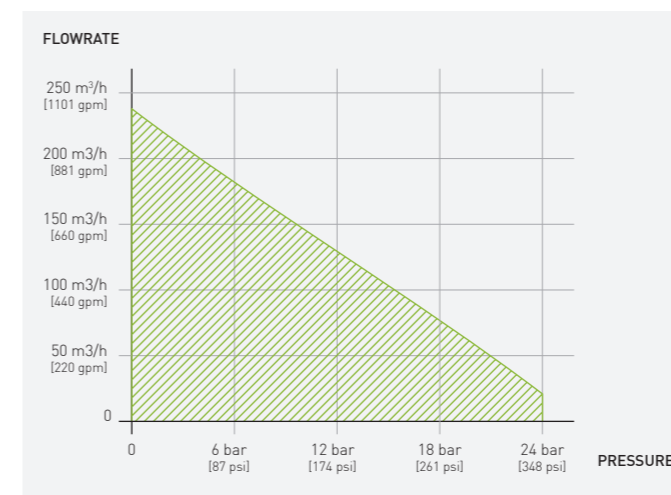

EXAMPLES OF APPLICATIONS

- Dosing of flocculants (environment)
- Metering of explosive products (mines and quarries)
- Preparation of coatings (paper)
- Dosing of chemicals (new energies)
- Metering of acids (chemistry)
- Galvanizing baths (mechanics)

PUMP CONSTRUCTION

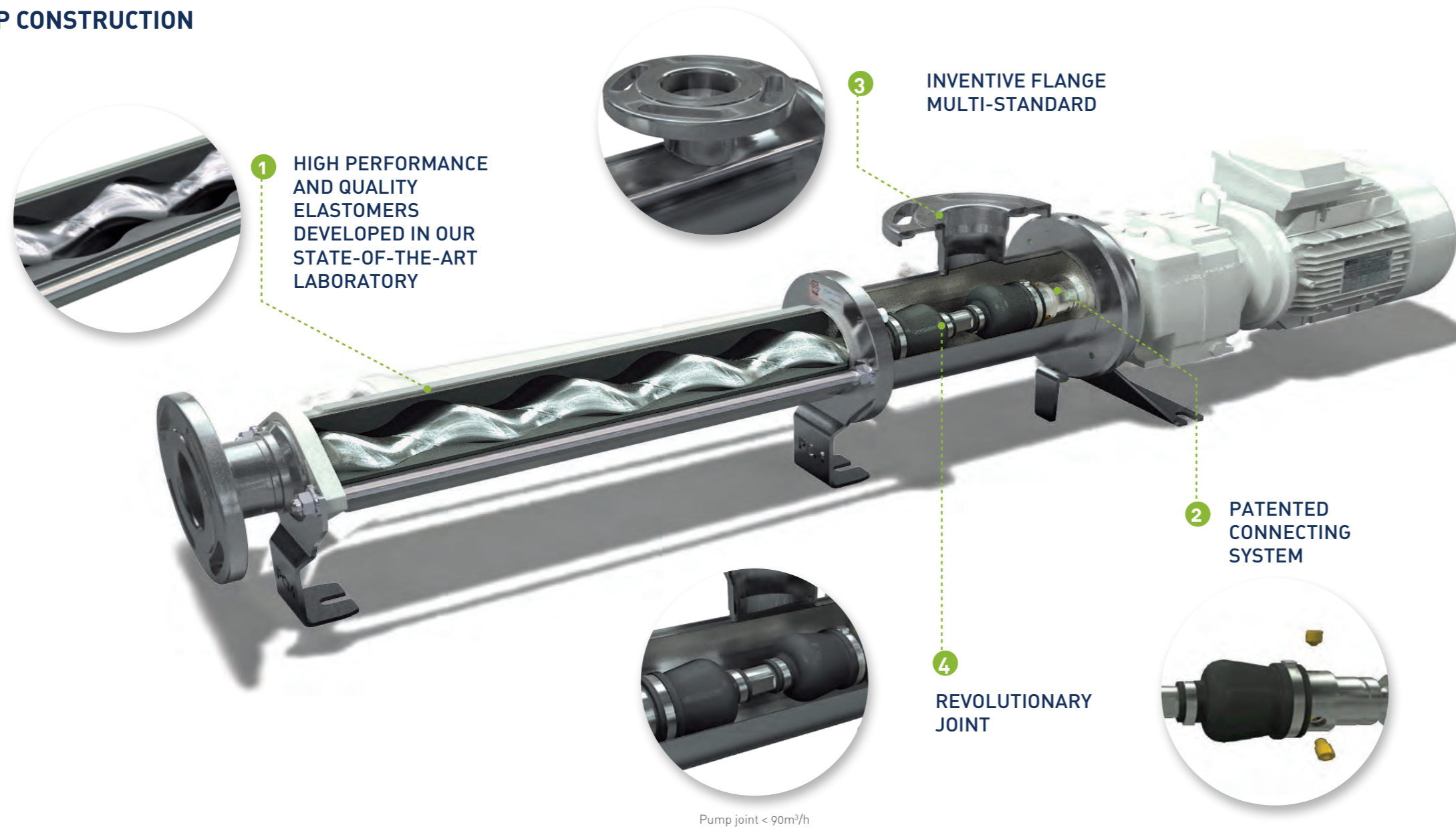

1 HIGH PERFORMANCE AND QUALITY ELASTOMERS DEVELOPED IN OUR STATE-OF-THE-ART LABORATORY

3 INVENTIVE FLANGE MULTI-STANDARD

2 PATENTED CONNECTING SYSTEM

4 REVOLUTIONARY JOINT

Pump joint < 90m³/h

Pump joint > 90m³/h

JOINT ASSEMBLY BENEFITS

- **Cost and stock savings:** same joint assembly for all models from the same module
- **Maintenance time saving:** 3 screws only to dismantle the joint. No sheath dismantling, nor usage of grease or oil.
- **Patented connecting system**
- **Durable and robust design:** lifespan increase for non corrosive and non abrasive applications



PCM ECOMOINEAU™ C RANGE BENEFITS

SPACE SAVING

- Revolutionary joint 80 % shorter than other PCPs on the market.
- Revolutionary joint coupling rod length reduced and hardened for long life operation
- Patented connecting system: only 10 cm of clearance required to dismantle the stator of the biggest models.

EASY AND QUICK DISMANTLING

- The seal can be changed by simply disconnecting the drive
- The shaft line (rotor, coupling rod, driving shaft) can be removed without disconnecting pipework
- Patented connecting system with 3 screws only

ECO-DESIGN PUMP

- 10% less power consumption compared to most Progressing Cavity Pump's on the market
- Less raw materials

VERSATILE CONSTRUCTION

Integrated construction

- Cost-effective solution including single bellow mechanical seal (self-positioning)
- Shortest and lightest design

Monobloc and bearing construction

- Five sealing solutions available
- Spacer with improved access to the sealing system
- Rubber deflector: protecting the drive and bearing

PCM ECOMOINEAU™ WITH FLOATING STATOR

The most compact Progressing Cavity Pump in the market



Based on the Moineau™ PCP technology, the **PCM EcoMoineau™ Progressing Cavity Pump with floating stator** is ideal for small space requirements. Using a floating stator without frame, this small PCP does not require connecting rod as used by conventional Progressing Cavity Pumps. **The flexibility of the stator allows the rotor to rotate eccentrically, as the rotor is directly connected to the drive. The pump body is consequently shorter.**

In many cases, this PCP with floating stator equipped with a frequency inverter can be used as a dosing pump. **It is an advantageous replacement for traditional dosing units for viscous, loaded and abrasive products.** Its compactness and robustness makes it particularly suitable for integration in machines and systems.



TECHNICAL PERFORMANCES

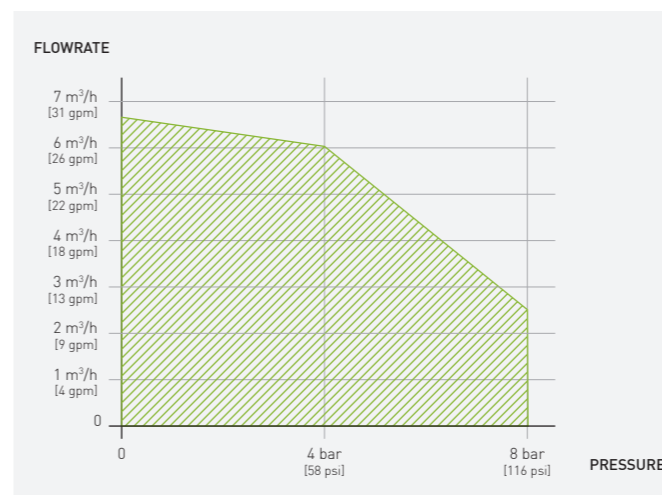

EXAMPLES OF APPLICATIONS

- Metering of chemicals (environment)
- Dosing of flocculants (mines and quarries)
- Preparation of glue and pigmentations (paper)
- Dosing of polymers (new energies)
- Handling of phytosanitary products (chemistry)
- Treatment of paints, varnishes, cataphoresis (mechanics)

› PUMP CONSTRUCTION



› PCM ECOMOINEAU™ WITH FLOATING STATOR RANGE BENEFITS

SPACE SAVING

- Compact size thanks to the rotor which is directly connected to the drive
- Easy integration to existing installation

QUICK AND SIMPLIFIED MAINTENANCE

- Shorter body
- Reduced weight
- No connection rod

VERSATILITY

- Simple and rugged construction in stainless steel or cast iron (depending of the pumped fluid)
- Dosing pump without pulsations
- Handles fragile and viscous products

LOW LIFE CYCLE COSTS (LCC)

- Simple design
- Cost-efficient maintenance
- Reduced weight

› PCM ECOMOINEAU™ WITH FLOATING STATOR OPTIONS & ACCESSORIES

AVAILABLE ACCESSORIES

- **Pressure sensor:** improves control of your process (manometer, pressure switch, pressure transmitter, combined pressure sensor)
- **Dry running protection:** the free stator principle is more tolerant to dry running. For complete protection, the dry running system controls product movement and protects the pump against stoppages or dry running, which may damage the stator.

OPTIONS

- **Trolley** which allows a mobile and versatile use of pump (easy fixing, stability, ergonomics)
- **By pass and/or safety valve** avoids the risk of pump damage in the event of overpressure and controls flow rate
- **Automatism** to control level, flow rate and pressure

› STAINLESS STEEL CONFIGURATION

- 7 models specially designed for highly corrosive applications
- Body / rotor / connections in ANSI 316L
- Several types of connections available in standard (SMS, DIN, MACON, CLAMP, IDF, RJT, ISO, ANSI)
- Same characteristics and hydraulic performances as the cast-iron versions



PCM ECOMOINEAU™ MSH/MVA/MVA-FF

Progressing Cavity Pumps with feeding hopper and conveyor screw



Based upon the Moineau™ technology, the PCM EcoMoineau™ MVA/MSH Progressing Cavity Pumps are designed to bring simplicity for transferring and/or dosing the many complex fluids found in a wide range of industrial applications.

High viscosity, pasty, sticky, high dry matters content, non-flowing fluids with big chunks or that have a

tendency to bridge are found across many industries and often entail challenging conditions.

With a simple rugged design, PCM EcoMoineau™ MVA/MSH Series allows you to combine constant productivity and cost-effectiveness even with the most complex fluids.



TECHNICAL PERFORMANCES

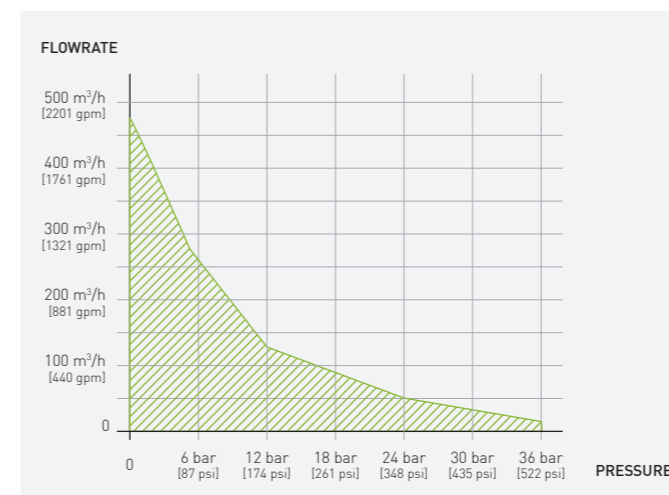

EXAMPLES OF APPLICATIONS

- Centrifuged & dehydrated sludge from urban and industrial origin, dewatered sludge recovery further to mechanical dehydration (belt-press, screw-press, centrifuge, filter-press) (Environment)
- Starches, glues, kaolin slurry, soapstock (pulp & paper)
- Cement milk, clay sludge, gypsum slurries, shotcrete, mortars, bentonite slurries, magnesium uranate, explosive preparations (minerals and construction)
- Grease, lubricant wastes, putties (mechanics)
- Viscose, pigments, precipitated silica production, styrene resin, paints (chemicals)
- Bio-mass application, bagasse, crop residues, liquid manure, cassava pulps (new energies)

PCM ECOMOINEAU™ MSH PUMP CONSTRUCTION

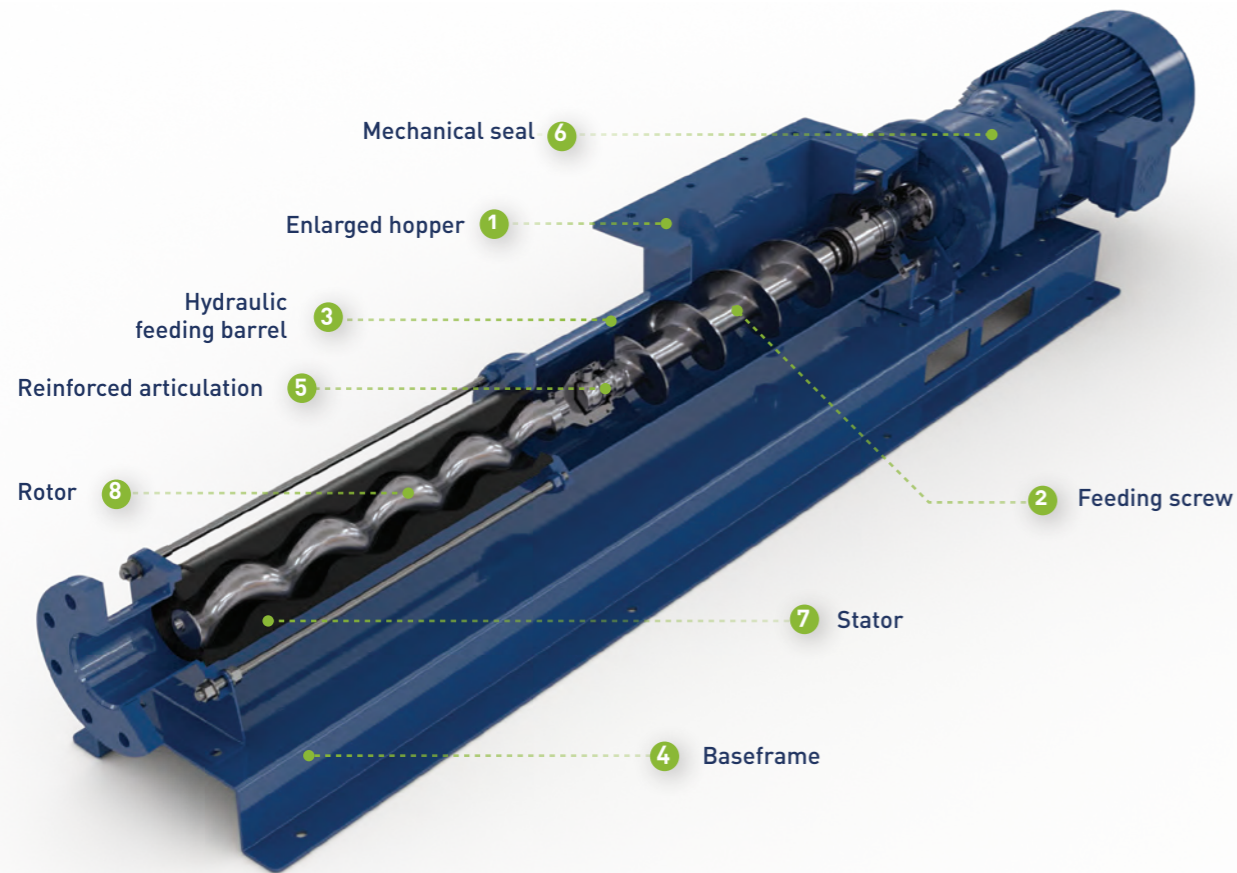

PCM ECOMOINEAU™ MVA PUMP CONSTRUCTION

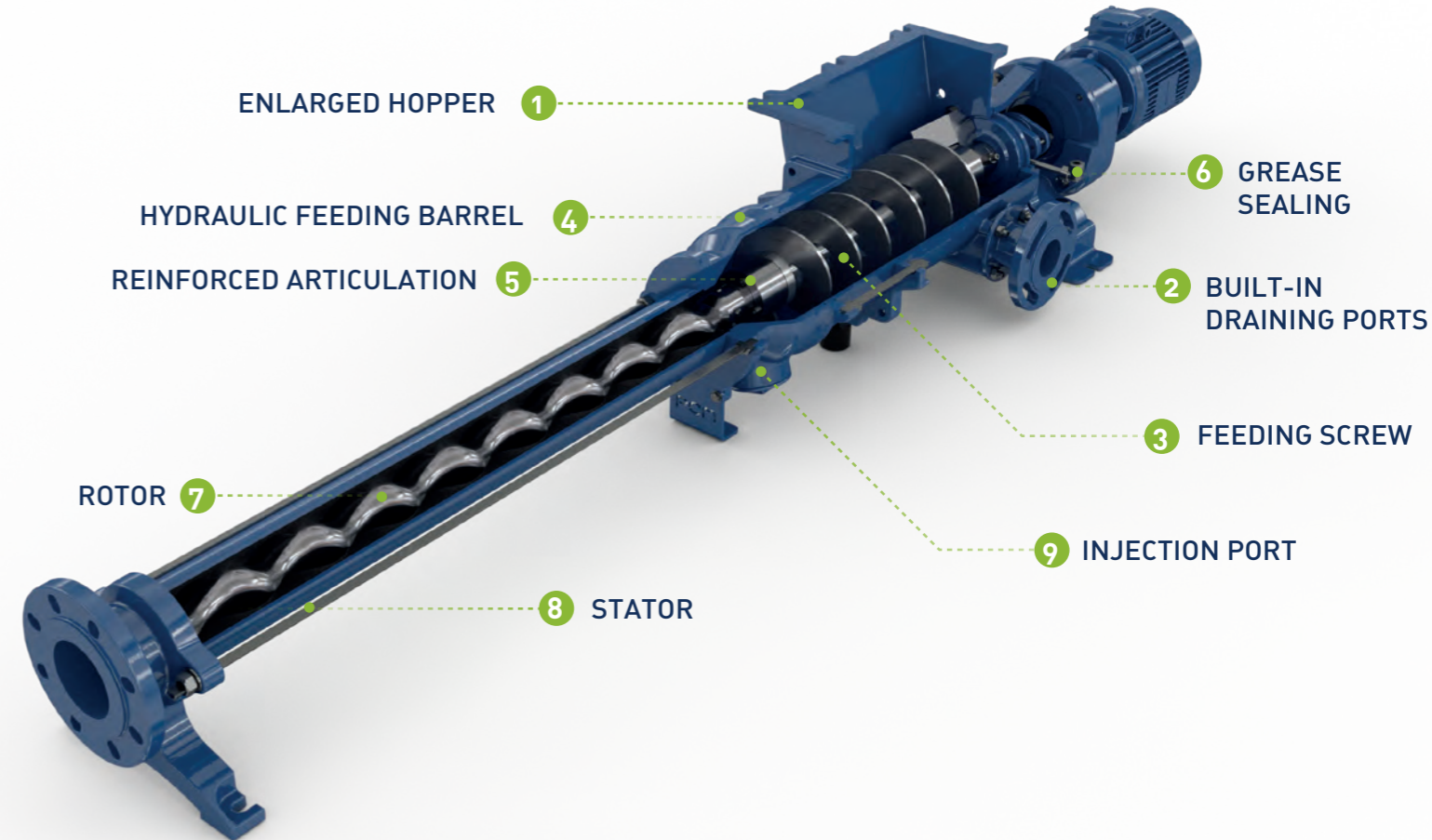

PCM ECOMOINEAU™ MSH RANGE BENEFITS

OPTIMAL FEEDING

- Optimal feeding of sludge and no risk of compacting thanks to the close auger
- High conveying performance for non-sticky viscous products



VERSATILITY

- Transfer of fluids with high viscosity or low capacity to flow thanks to the open screw profile
- Handling of fluids requiring manual feeding or gravity fed pumps through the enlarged hopper
- Compact and robust articulation

Vis d'Archimède fermée

EASY MAINTENANCE

- Joint with rotor grip system with the patented 3-screws system for large capacity models.



PCM ECOMOINEAU™ MVA RANGE BENEFITS

VERSATILITY

- Transfer of fluids with high viscosity or low capacity to flow thanks to the open screw profile
- Handling of fluids requiring manual feeding or gravity fed pumps through the enlarged hopper
- Reinforced articulation (metal casing) adapted to abrasive fluids



Vis d'Archimède ouverte

REDUCED MAINTENANCE TIME

- Sliding feeding barrel to facilitate maintenance
- Only 15 cms [5.90 inc] of clearance are required to replace the stator and the rotor
- 3 screws only to complete maintenance of the shaftline
- Built-in draining ports on both sides allowing draining, preventing corrosion from residual fluid
- Grease sealing: cost effective and automatic lubrication dispensing self-contained lubricant at the desired rate of the residual level

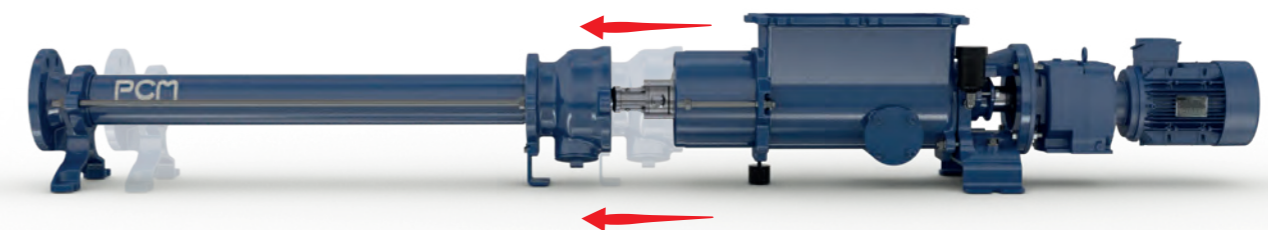

PCM ECOMOINEAU™ MVA-FF PUMP CONSTRUCTION

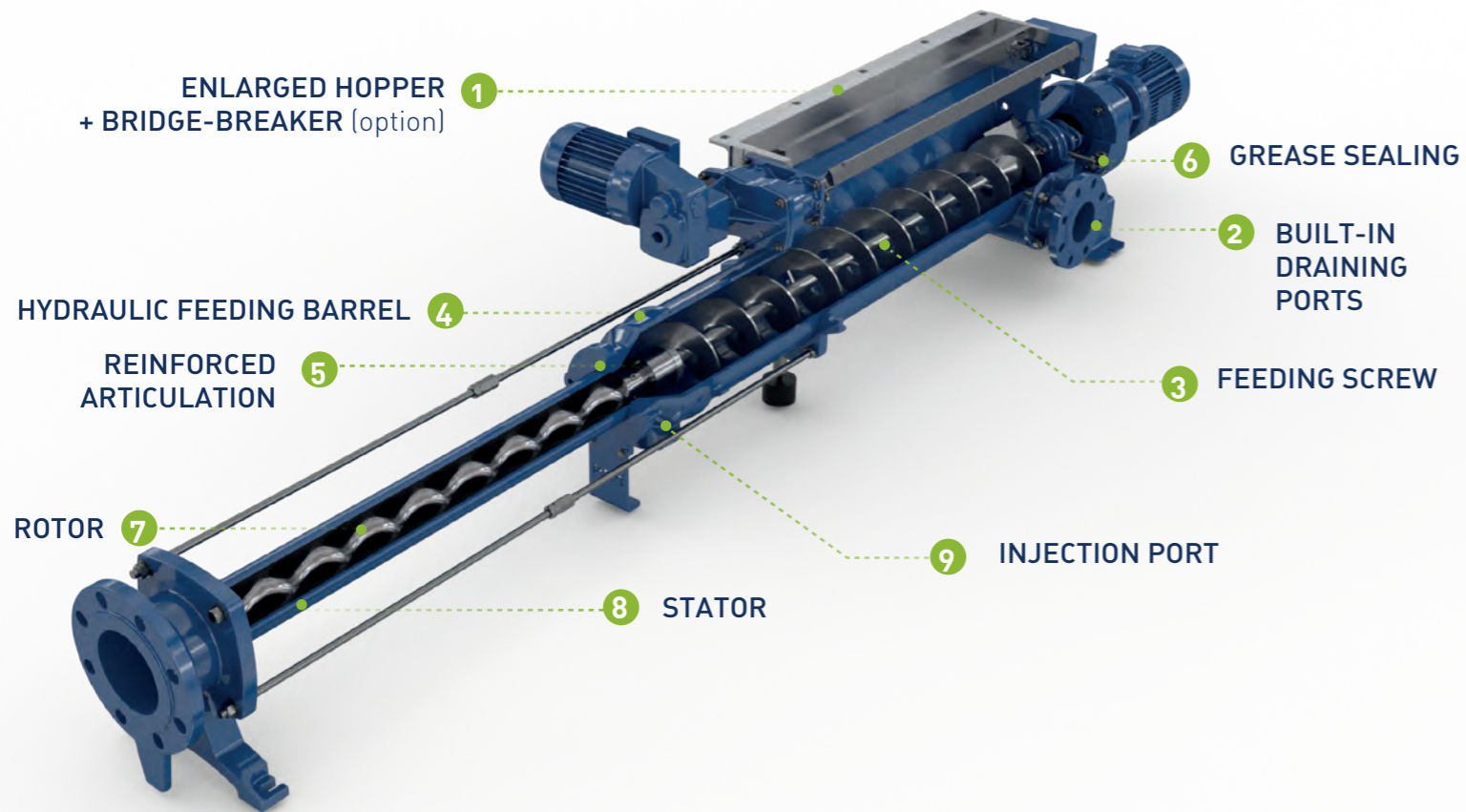

PCM ECOMOINEAU™ MVA-FF RANGE BENEFITS

EASY MAINTENANCE

- Built-in draining ports (DN50) allowing complete, draining, preventing corrosion from residual fluids
- Grease sealing: cost effective and automatic lubrication dispensing self-contained lubricant at the desired rate of the residual level

VERSATILITY

- Transfer of fluids with high viscosity, high dry matter, sticky with a low capacity to flow or that tend to bridge thanks to the open screw profile
- Handling of fluids requiring manual feeding or gravity fed pumps through the enlarged hopper
- Reinforced articulation (metal casing) adapted to abrasive fluids

OPTIONS

Polymer lubrication system recommended when transferring over long distances

- Reduction of operating costs
- Reduction of discharge pressure
- Reduction of strain on wearing parts

Flow management level control module

- Control of the pump speed
- Prevention of overflow

Control hopper for optimized process allowing manual feeding batch or gravity-fed when placed underneath dehydrating equipment.

PCM ECOMOINEAU™ MVA-FF OPTIONS

Polymer lubrication & level management

Polymer lubrication as an add-on option is highly recommended when transferring over long distances. The injection of a lubricating layer on the discharge pipe internal diameter guarantees better yield and reduced operating costs.

- Reduction of discharge pressure
- Reduces strain on wearing parts

Flow Management: level control module controlling the pump speed and preventing overflow

- adaptable to equipment configurations
- variable flow-rates functioning
- suitable for difficult environments
- compatible with lime treatment configuration



Level control module

Control hopper for optimized process

The control hopper adapts to up-stream process, from manual feeding batch or gravity-fed when placed underneath dehydrating equipment.

Made to measure, the control hopper:

- includes the sludge loading zone,
- has one or several visit holes to ease inspection,
- facilitates the incorporation of accessories such as level sensors,
- accomodates lime injection and relevant air-vent port.

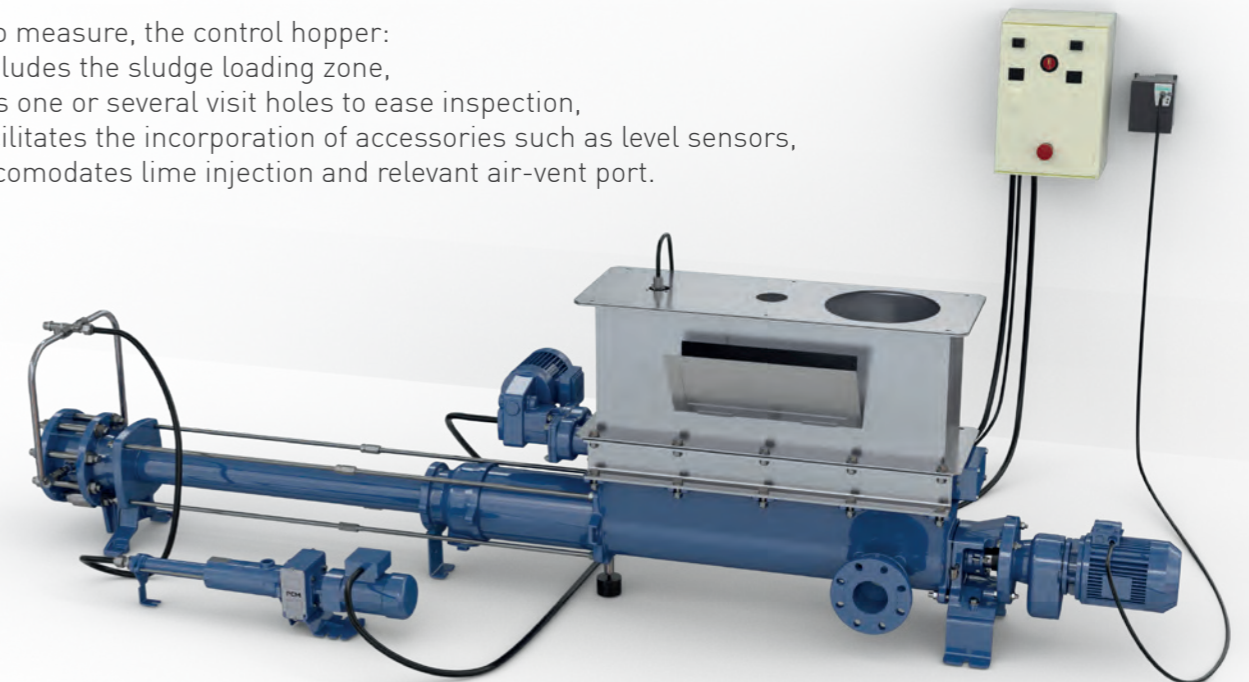

PCM DELASCO™ PERISTALTIC PUMPS

The ideal choice to reduce maintenance costs

▶ PRINCIPLE OF PCM DELASCO™ TECHNOLOGY

The peristaltic pumping principle is based on the capacity of a soft elastomer hose to accept a deformation and subsequently recover its initial shape. Peristaltic pumps are provided with either high or low pressure hoses, covering a wide range of applications which need versatility and flexibility.

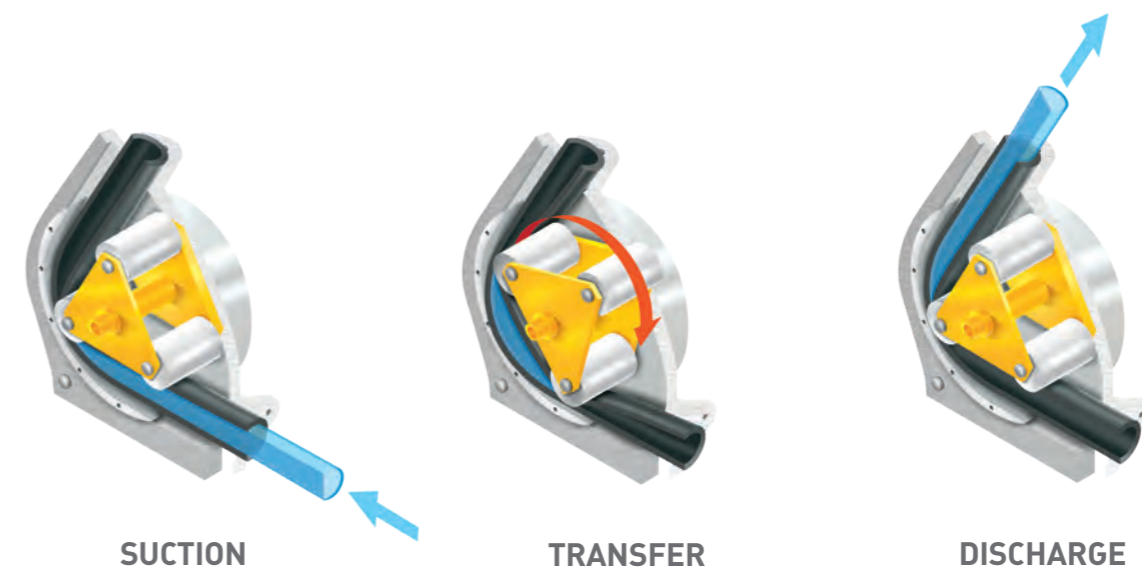

▶ BENEFITS

- Media Purity (only one wearing part: the hose)
- Gentle Pumping action
- Seal-less design
- Self-priming
- High suction capacity
- Simplified maintenance
- Low life cycle costs
- No mechanical seals, valves or gaskets
- Reversible

▶ RANGE OF PCM PERISTALTIC PUMPS

- PCM DX Series
- PCM Z Series
- PCM PMA Series



PCM DELASCO™ - DX-Z-PMA SERIES

Peristaltic pumps for corrosive, abrasive and fragile products



With various pump constructions and a wide choice of elastomer hoses, the PCM Delasco™ range covers a **wide variety of applications** calling for heavy-duty and flexibility.

Simple to use and to maintain, PCM Delasco™ peristaltic pumps are well suited for a variety of demanding conditions of services.

Peristaltic pumps with low operating speeds are ideal for **fragile and/or abrasive products**: the transfer is carried out inside the hose without agitating or frothing the fluids.

They are also the perfect solution to handle **corrosive products** as only the hose is in contact with the fluid.



TECHNICAL PERFORMANCES

- **Pressure:**
 - DX Series: up to 15 bar [218 psi]
 - Z Series: up to 3 bar [44 psi]
 - PMA Series: 1.5 bar [22 psi]
- **Flowrate:**
 - DX Series: up to 100 m³/h [440 gpm]
 - Z Series: up to 20 m³/h [88 gpm]
 - PMA Series: up to 0.20 m³/h [0.88 gpm]

EXAMPLES OF APPLICATIONS

- Dosing of chemical products (environment)
- Mortar grout transfer (mines and quarries)
- Wastewater treatment (paper)
- Transfer of slurry (new energies)
- Manufacturing of foam (chemistry)
- Degreasing baths or stripping baths (mechanics)

PCM DELASCO™ - DX SERIES

› PUMP CONSTRUCTION

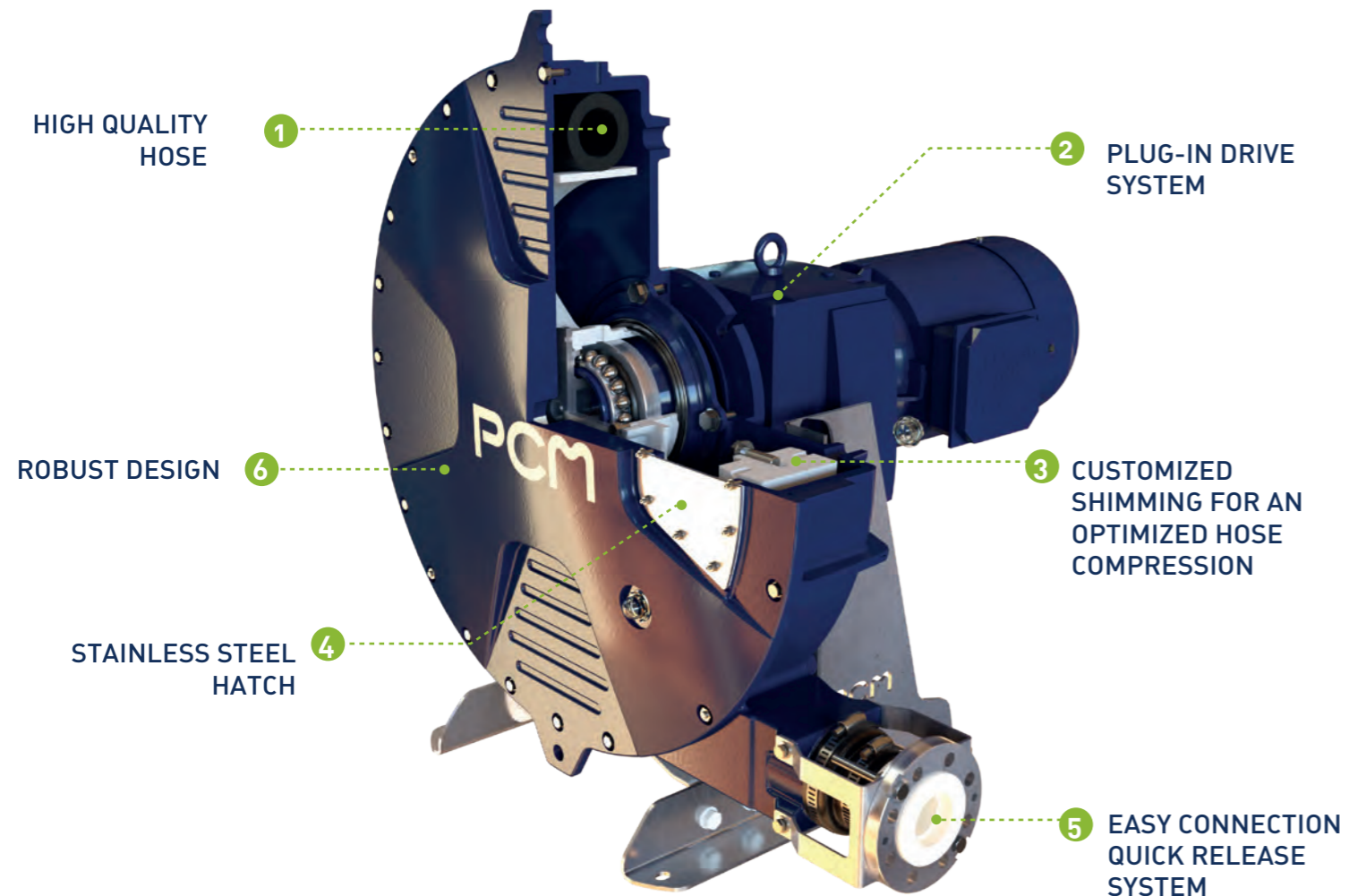

› PCM DELASCO™ DX SERIES BENEFITS

ONE PUMP FOR ALL FLUIDS

- Ideal for abrasive and high solids content slurries (up to 80%), high density, corrosive, shear sensitive, viscous, multiphase, gaseous and crystalizing fluids pumping

OPTIMISED OPEX FOR TOUGH APPLICATIONS

- Only one wearing part: the hose;
- Seal-less design: no expensive sealing to replace and no associated seal-water flushing costs
- Low energy requirements thanks to the inherent low running speed
- Progressive hose compression system to extend hose life thanks to the unique lemon shaped rotor and deflector design

VERSATILITY

- One pump for all tasks : transfer, dosing, emptying
- Self-priming
- High suction lift
- Reversible
- Can run dry without ancillary protection equipment

DISASTER / CONTAMINATION PROOF TECHNOLOGY

- 100% leak proof body to hold the fluid in case of hose rupture through the double seal and bearing barrier, the integrated buffer zone and the sheath around the connection

EASY AND QUICK MAINTENANCE

- Easy on-site maintenance and short downtimes thanks to a unique hose quick release allowing hose change in only a few minutes

COMPACT FOOTPRINT

- Integrated bearing design allowing to feature one of the smallest footprints on the market

ROBUST DESIGN

- Shock resistant heavy cast X-cover design
- Improved ergonomic design with accessories connected at the pump back

› ACCESSORIES

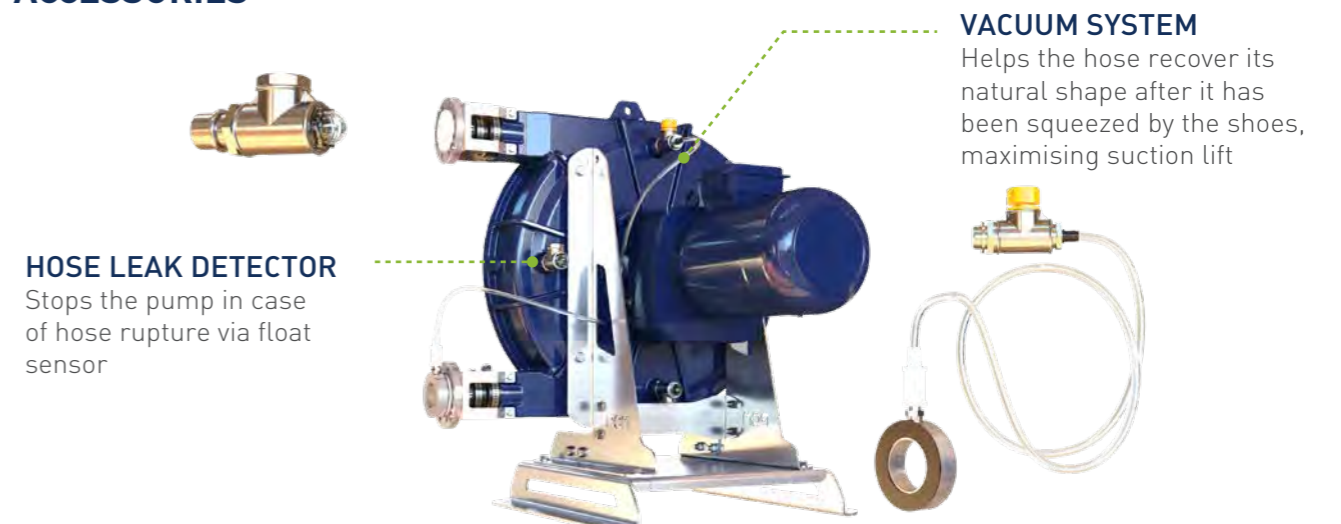

PCM DELASCO™ - Z SERIES

› PUMP CONSTRUCTION

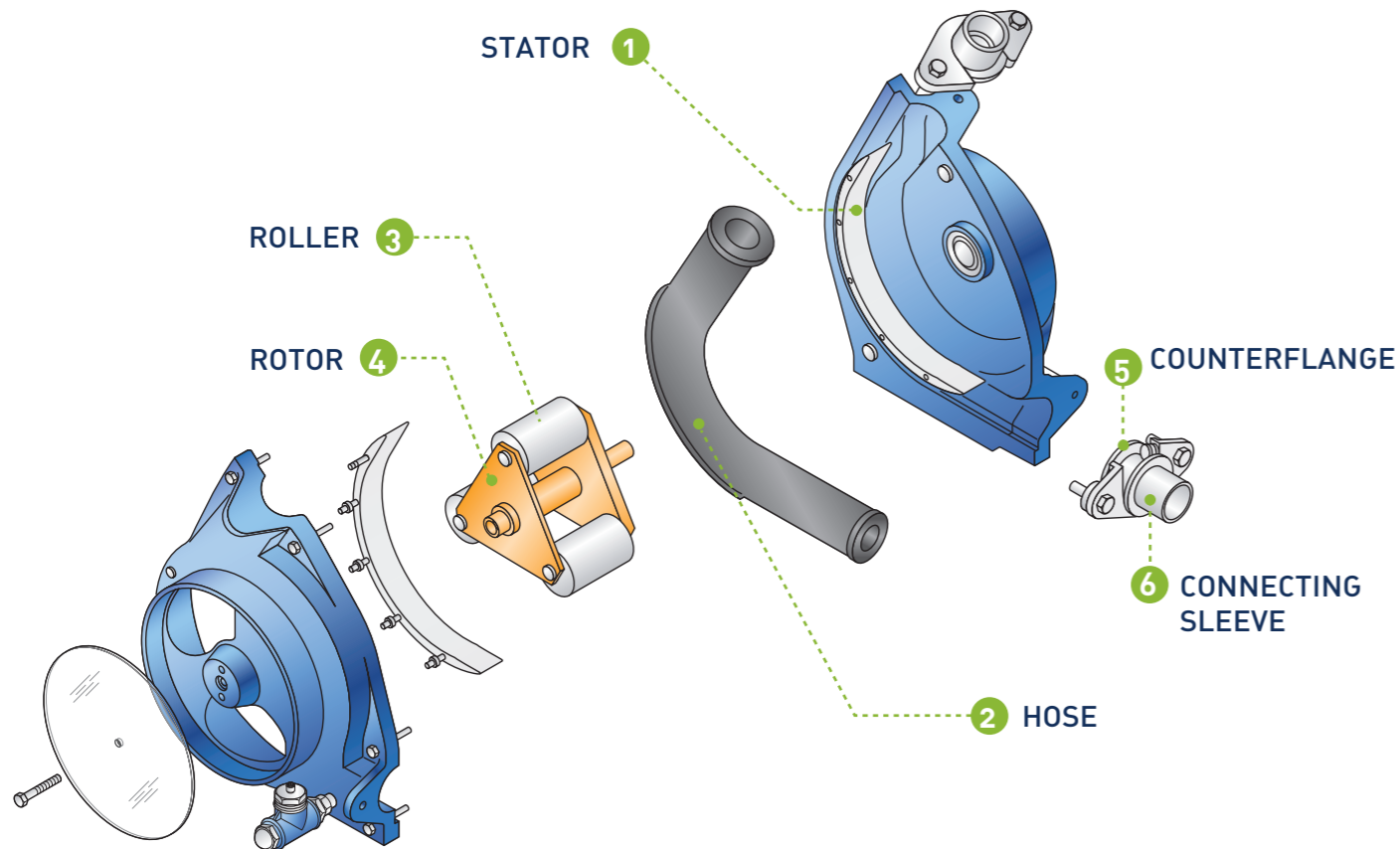

› PCM DELASCO™ Z SERIES BENEFITS

EASY AND QUICK MAINTENANCE

- Only one wearing part: the hose
- Maintenance is limited to regular lubrication.
- The hose can be changed without dismantling the pump

VERSATILITY

- Dosing and transfer of low flowrates
- Handles corrosive, abrasive and fragile products
- Dry running operation is possible without damage occurring

REDUCED LCC

- Reduced maintenance time and costs
- Reduced consumption of energy

› OPTIONS

- **Pump mounted on a trolley**
- **Leak detector** senses possible dry running which makes it possible to stop the pump in case of a hose burst
- **Integrated or external frequency inverter** for pump on base or trolley
- **Starter and connector** for pump on base or trolley

PCM DELASCO™ - PMA SERIES

› PUMP CONSTRUCTION

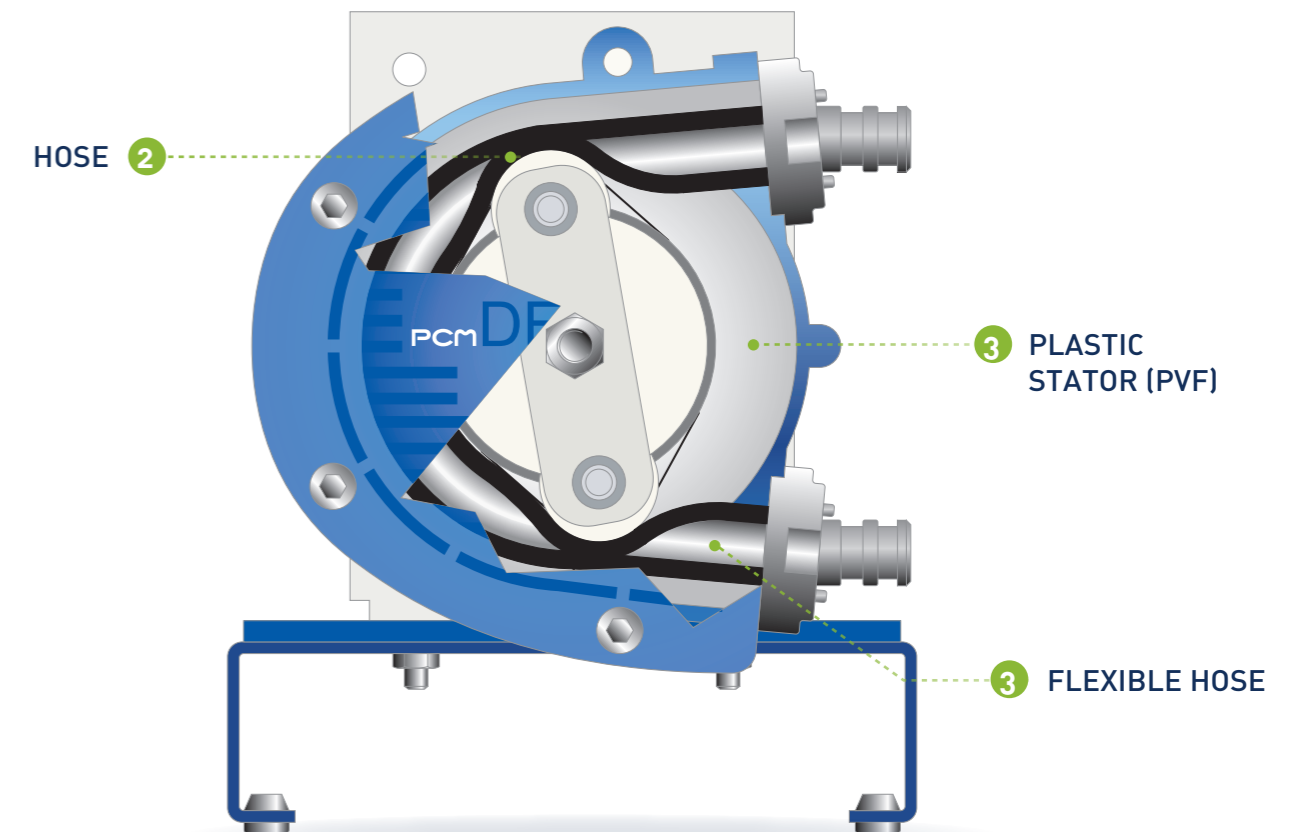

› PCM DELASCO™ PMA SERIES BENEFITS

EASY AND QUICK MAINTENANCE

- Only one wearing part: the hose
- Compact pump

VERSATILITY

- Dosing and transfer of low flowrates and low pressure
- Better resistance to corrosion thanks to the plastic stator
- Reversible pump

REDUCED LCC

- Reduced maintenance times
- Low cost spare parts
- Low OPEX and CAPEX

PCM LAGOA DIAPHRAGM DOSING PUMPS

Accuracy and reliability: ingredients of successful dosing

PCM LAGOA TECHNOLOGY PRINCIPLE

The PCM Lagoa pump is composed of a diaphragm connected to a piston which alternating movement successively fills and empties the pumphead.

1- The backward movement of the diaphragm opens the bottom check valve and allows the entry of fluid, which fills the pumphead.

2- The forward movement of the diaphragm closes the bottom check valve, opens the top check valve and expels the dose.

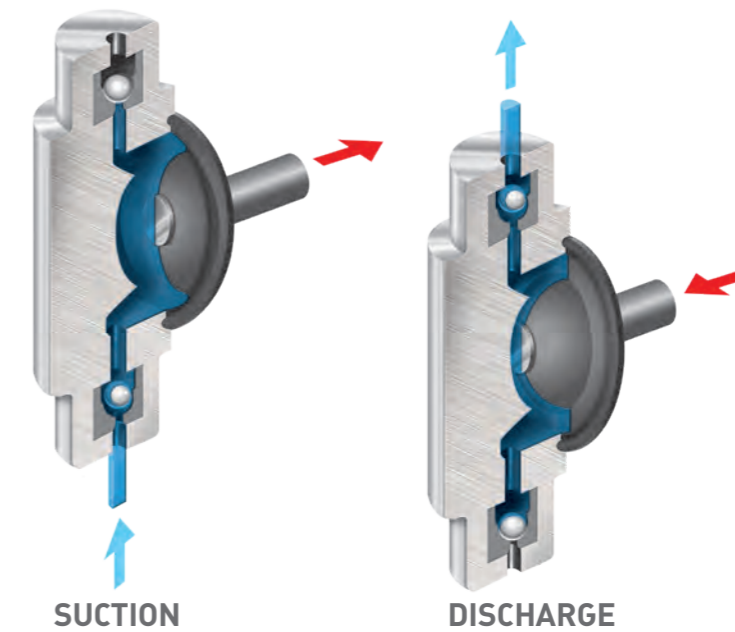

BENEFITS

- Reliability of metering
- Simplified maintenance
- Dry-running
- Simple and robust

RANGE OF PCM DIAPHRAGM DOSING PUMPS

- PCM Lagoa





PCM LAGOA

The simple and reliable diaphragm dosing pump



The PCM Lagoa Series is designed for metering a wide variety of products in chemical engineering and environmental applications.

The pump is driven by a direct mounted light alloy maintenance-free motor with IP55 protection. The part of the diaphragm in contact with the pumped liquid is in chemically inert PTFE and pumpheads are available

in several material combinations to better match with the fluid characteristics. The capacity of the pump is set by adjusting a micrometer graduated dial that can be locked in position to ensure that the setting does not change inadvertently.



TECHNICAL PERFORMANCES

- **Maximum flowrate:** 315 l/h [1.39 gpm] per pumphead
- **Maximum pressure:** 12 bar [174 psi]
- **Maximum temperature:** 90°C

EXAMPLES OF APPLICATIONS

- Dosing of chemicals products (environment)
- Dosing of flocculants (mines and quarries)
- Preparation of coatings (paper)
- Dosing of polymer (new energies)
- Treatment of reagents / additives (chemistry)
- Metering of chemical products (mechanics)

› PUMP CONSTRUCTION

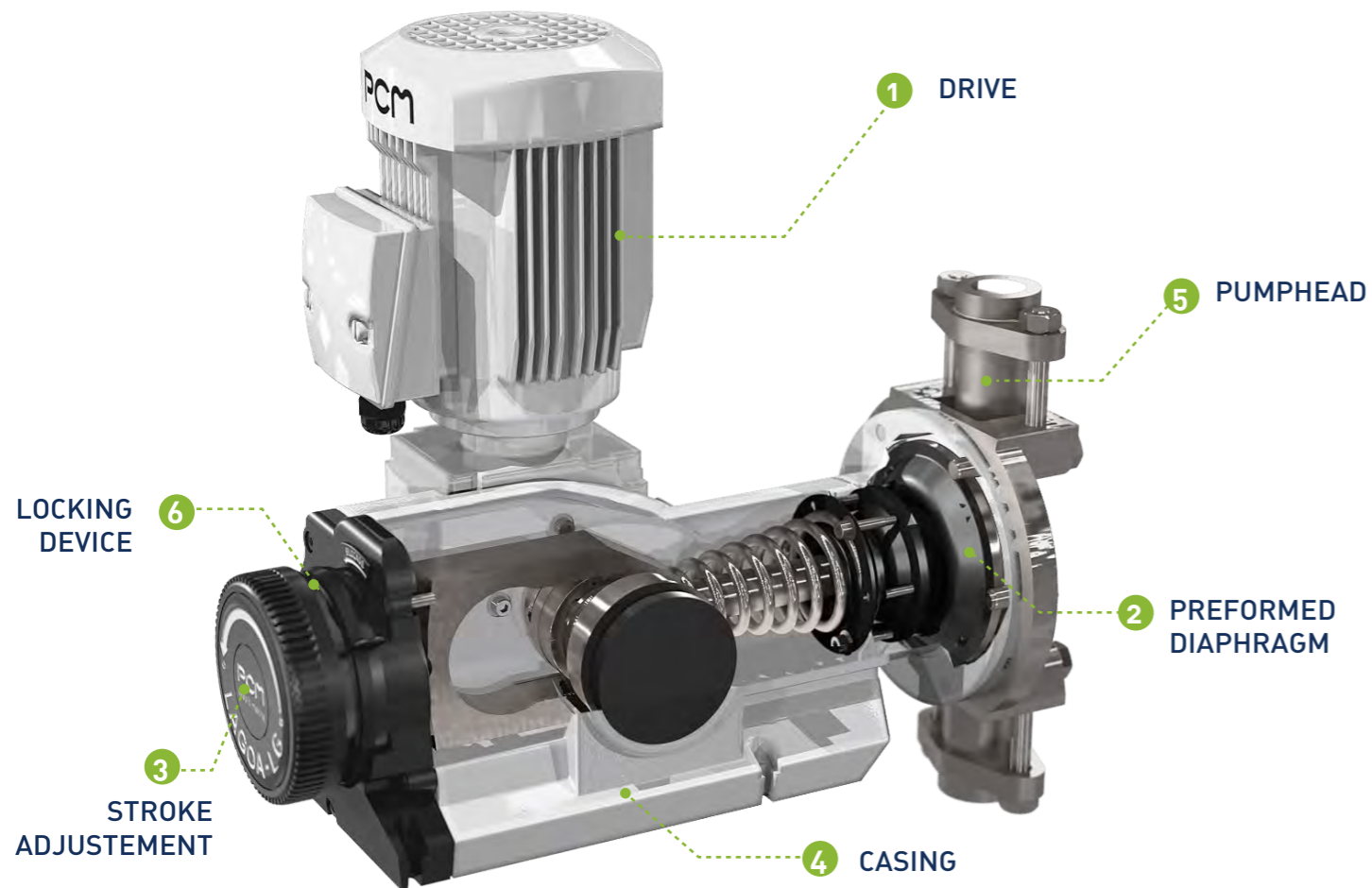

› PCM LAGOA RANGE BENEFITS

SIMPLE AND ROBUST CONSTRUCTION

- The pump is driven by a direct mounted light alloy motor with IP55 protection.
- The casing is made of cast aluminium alloy.

RELIABILITY

- Reliability of metering.
- The stroke adjustment mechanism can be locked in position to ensure that stroke length remains at its set point.

VERSATILITY

- Dosing of a wide range of fluids.
- Pumpheads are available in many material combinations. It consists of 1 suction check valve, 1 discharge check valve, 1 liquid end body.
- Dry-running.

SIMPLIFIED MAINTENANCE

- The bearings are greased for life, making the motors maintenance-free.
- The capacity is set by turning the micrometer dial which is fitted with vernier scale graduated in percentage stroke length. Electric servo control can be fitted.
- The pumphead is easy to remove and change.

ELECTRO-MECHANICAL DRIVE

- Does not cause and is not affected by interferences
- Reduced mechanical and hydraulic shocks
- Silent

› OPTIONS AND ACCESSORIES

FOOT VALVES

- Filter undesirable particles and keep the pump primed when stopped

INJECTION LANCE

- Enables your product to be injected in a vein without polluting the injection pipework (non-return function)

SAFETY AND RETENTION VALVES

- Prevent excess flow and pressures, siphoning and underloading

PULSATION DAMPERS

- To render your flow linear and lessen fluid hammer effects

"READY-TO-METERS" ASSEMBLIES

- Connecting system to the entire pump

› PCM LAGOA MULTIPLEXING BENEFITS

- Perform proportional metering with different fluids
- Obtain a greater flow than with one single pumphead
- Phase the pump stroke to prevent pulsations and thereby achieving linear flow



PCM GRINDERS & MACERATORS

A cost effective way to protect pumps and other downstream equipment

▶ INLINE GRINDERS PRINCIPLE

Many industrial processes for the transfer or dosing of fluids are about products like effluent, sludge or other waste type often loaded with solids or semi-solids. In order for the pumping of such fluids to remain possible, it is important that the installations used have grinding equipment capable of reducing the solids to fine particles in order to protect the downstream equipment without slowing down or interrupting the entire process.

PCM offers technologies that are well suited to different types of waste to be grinded and offers a macerator for filamentous string-type materials and a grinder for solid wood, plastic or pebble material.

The **PCM Macerator** is a simple and reliable solution for the protection of pumps using a proven concept based on a perforated plate and a rotary cutting head. This macerator protects the pumps against fibers, filaments and stringy particles of large size. Thanks to its cartridge cutter system, the **PCM X-Guard** has been designed to shred solid pieces into small and fines particles. It allows to remove solids waste from fluids before they are processed and can damaged your process equipment.



▶ BENEFITS

- Protection of the pump reliability
- Protection of the downstream equipment
- Simplified maintenance
- Low life cycle costs
- Optimal cutting and grinding performances

▶ RANGE OF PCM GRINDERS

- PCM X-Guard
- PCM Macerator

PCM X-GUARD

In-line grinder to shred solid pieces in fluids before they can damage your downstream equipment

The **PCM X-Guard** in-line grinder reduces tough wastewater solids to fine particles. It grinds and shreds rags, pieces of wood, plastics or any other solid or semi-solid pieces that could otherwise clog valves, damage pumps or any other downstream equipment.

Its cartridge cutter system, extremely robust and delivering high torque at low rotational speeds, is ideal for improving the performance of treatment and dewatering equipment for sludge or highly charged fluids.

PCM X-Guard prevents costly damages, time consuming repairs, or unplanned maintenance operations. Furthermore, PCM X-Guard can contribute to a better performance of the sludge treatment or dewatering equipment in helping to better precondition the sludge.



TECHNICAL PERFORMANCES

- **Flowrate:** up to 65l/sec (234m³/h) [1030 gpm]
- **Particles:** reduced to 5-6 mm

EXAMPLES OF APPLICATIONS

- Dewatering equipment protection in waste water treatments
- Clothes, rags, stones grinding in mining applications
- Preconditioning organic waste in biomass applications



PCM X-GUARD CONSTRUCTION

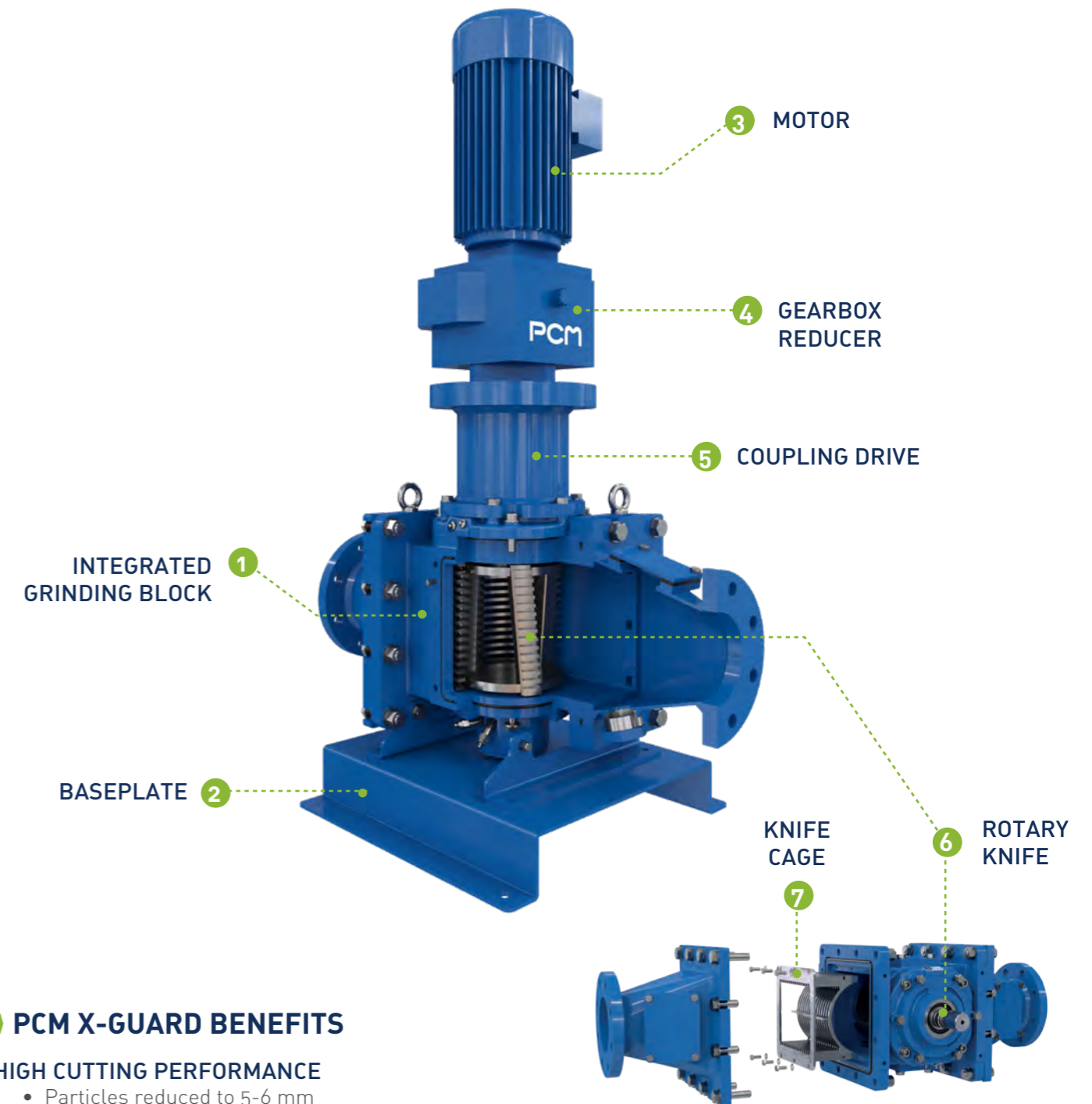

PCM X-GUARD BENEFITS

HIGH CUTTING PERFORMANCE

- Particles reduced to 5-6 mm
- High torque / low speed
- Heat treated steel cutters

SIMPLE MAINTENANCE

- Single shaft design
- Cutters cartridge design
- Slide inspection hatch

MULTI-BRAND DRIVE MOUNTING

- Bearing drive mounting with elastic coupling

LOW IMPACT ON HYDRAULICS

- Less than 0.5 bar head loss

PCM MACERATOR

The pump protection from rags, fibers and long particles for all water works

PCM Macerator offers a cost-effective way to protect the reliability of the pumps.

It can protect the pumps from rags, fibers and solid particles, using a proven concept which is based on a perforated shear plate and a rotating headstock.

Suitable for all water works, it offers the pump protection from fibers and long particles, the improvement of preconditioning in the primary treatment. It is also able to replace in-flow grinders.

Specially designed for sludge applications, **PCM Macerator** is suitable for new water plants or as a retrofit for old pipeliners. It can also be used as protection for pumping stations handling raw sewage, as well as maceration and mixing in a range of industries, from paper to oil.



TECHNICAL PERFORMANCES

- **Flowrate:** up to 111 l/sec [400 m³/h] [1761 gpm]
- **Fluid concentration:** up to 150 g/l

EXAMPLES OF APPLICATIONS

- Primary sludge in waste water treatments
- Pump protection from fibers and long particles
- Improvement of biological sludge preconditioning

PCM MACERATOR CONSTRUCTION



PCM MACERATOR BENEFITS

EASY MAINTENANCE

- Few spare parts
- Interchangeable cartridge assembly
- Easy access to stone traps on both sides to clean out sump

OPTIMAL CUTTING PERFORMANCES

- Shearplate and headstock assembly designed for a smoother cut

COMPETITIVE THROUGH LOWER COST OF OWNERSHIP

- Lower running costs
- Less power requirements
- Reduced downtime for routine servicing
- Protection of the downstream pump reliability



AT YOUR SERVICE

In order to provide the best use of our pumps and pumping systems, we offer a wide range of pre- and post-sales services.

All of our services are designed with one goal in mind: optimising the performance of PCM pumps. From preventive maintenance to spare parts management, from equipment upgrading to training, we can strongly contribute to the productivity of our customers.

› EXTENDED WARRANTY

The extended warranty ensures:

- an extension of our guarantee according to our General Sales Conditions,
- the best solution for delayed installation or commissioning cases,
- the peace of mind at a reasonable cost.

Our extensive service includes also an extension for the general guarantee conditions for a period from one to four years according to your requirements.

› TESTS

To ensure the performance and lifespan of a pump or a system, it is vital that the equipment is engineered to meet the needs of the materials being handled. That is why we provide a wide offer of tests:

- chemical compatibility tests,
- viscosity tests,
- abrasiveness tests.

› TRAINING

In order to support and train the professionals who handle our pumps, we can arrange training sessions either at customers sites, or PCM facilities.

The PCM training enables the participants to maintain the value of the pump to minimise the consequential costs for maintenance or service even more.

› MAINTENANCE, REPAIRING & UPGRADE

We offer a full range of services to ensure optimum operation of your pumps as well as time and cost savings.

Maintenance services for PCM pumps are provided by our highly trained engineers. This ensures that pumps are maintained at optimal operating levels. Our careful monitoring and expertise helps to minimise production downtime and increase the global run life of the system.

We provide a wide range of after-sales services:

- maintenance on customer's site,
- PCM workshop maintenance,
- maintenance contracts,
- mechanical seals and rotors refurbishment,
- systems upgrade.

› SPARE PARTS

Thanks to our worldwide network of sales agencies and distributors, you can obtain genuine PCM spare parts quickly. Using PCM spare parts ensures that PCM products last as long as possible, benefit from warranty protection and maintain their CE conformity until their end of life.

PCM experts are dedicated to spare parts and answer your request in the shortest time. Thus, available standard PCM spare parts can be delivered within 24hrs (depending on the location).

› INSTALLATION AUDITS

The Life Cycle Costs audit will optimise the use of your pump while reducing costs related to inefficiency, rationalising your stock of spare parts and controlling your overall costs.

Our extensive service includes:

- a complete inspection of your facilities,
- an analysis of your spare parts consumption,
- a detailed report and our recommendations to help you optimise your costs.

› COMMISSIONING

PCM pumps are simple to use and efficient as long as they are installed and commissioned properly.

Through pre-operational checks and close monitoring of all equipment, our installation services implement stable and secure production.

Our installation services take the guesswork out of integrating a new pump into an existing system or installing a new pump from scratch. We provide start-up assistance, system integration engineering and training for operators.

The logo for PCM, consisting of the letters 'PCM' in a bold, blue, sans-serif font.

keep it moving